

BALCONY VIEWS magazine

Innovative design solutions for contemporary building



Welcome to Balcony Views Magazine



Effi Wolff
Editor

Balcony Views Magazine is an exciting and effective way of communicating ideas, innovations, practical information and design concepts to architects, contractors, developers and self-builders.

Welcome to issue III of Balcony Views Magazine. The magazine showcases Balcony Systems' products by focusing on real life projects where they've been used.

As a leading manufacturer and supplier in the fields of Glass Balconies, Curved Glazing and Decking we want to inspire designers, developers and home builders with our wide range of solutions.

The magazine is full of interesting projects both small and large scale that cover many different buildings, renovations and developments. In this issue we have also incorporated and included more in-depth technical information.

Whether you are an architect, in the trade, building your own home or simply like beautiful products, we hope our magazine inspires you and gives you some new ideas.

Enjoy the read . . .



Published by	Balcony Systems Solutions Ltd
Editor	Effi Wolff
Design	Heather Dewhurst, Design to Print UK
Copywriter	Kathy Wilkinson

The content of this magazine is copyright of Balcony Systems Solutions Ltd. All rights reserved. Any redistribution or reproduction of part or all of the contents in any form is prohibited other than the following:

1. You may print extracts for your personal and non-commercial use only.
2. You may copy the content to individual third parties for their personal use but only if you acknowledge the magazine as the source of the material.

You may not, except with our express written permission, distribute or commercially exploit the content.

Cover photo: Kathy Wilkinson



SUBSCRIBE

To subscribe to your **FREE** copy of **Balcony Views Magazine** please visit:

www.balconyviews.co.uk or call **01342 410411**

For information on all our products and services please visit:

www.balconette.co.uk



Contents

What Balcony Systems can do for your home Pages 4-16

In this section we showcase how our products can enhance your home and what we can offer self-builders, home improvers and small developers.



Balcony Systems for house builders Pages 19-33

Showing off some of our larger projects in this section, we show our products installed and present ideas and solutions for house builders, contractors and larger scale developers.



Technical details Pages 35-46

Eleven pages containing technical information about our Juliet Balcony Systems, Glass Balustrade Systems and Curved Door Systems.



BalcoNano® Pages 47-52

In this section we talk about our BalcoNano® Advanced glass coating, how it works and what it can do for you.

Balcony Systems' Composite Decking Pages 53-59

A new generation of Composite Decking, the future is here with a completely wood free decking solution.

About Balcony Systems Solutions Ltd Pages 61-63

In this section you can read about us and how we can work together.

What Balcony Systems can offer you on your self build or renovation project

If you are undertaking a conversion, renovation or new-build project, Balcony Systems can provide a range of solutions that enable you to incorporate that “extra something”, a little bit of “wow” factor, without overstraining your budget or putting obstacles or complications in the way of your push for completion.

Bringing together experience, expertise and technical innovations, our products enable you to combine a high aesthetic appeal with practicality in terms of installation, maintenance, quality of product and, of course, affordability.

Every project is unique and whether applied to a loft conversion, internal or external renovations, extensions, patios, decking or balconies, we can provide a flexible range of possibilities to suit your specific requirements or, indeed, your imagination.

The aesthetic appeal provided by Balcony Systems products is self-evident as you will see from the completed projects and customer testimonials featured in the following pages. In addition we can provide you with full back-up in terms of help with the design and technical specifications, structural calculations and even the choice of the finishes and colours.

Alongside the quality, strength and durability of our balconies, balustrades, patio doors and decking

there is also timeliness of delivery and straightforwardness of installation, bolstered by full technical support and a nationwide network of installers should you need the help.

In other words, we work with you to create a smooth process that takes you from your initial idea right on through design, delivery, fitting and installation, to the finished product.

But it does not end there. Our products also incorporate protective finishes to glass and handrails that mean they require virtually no maintenance and minimal cleaning to keep them looking “as new” for many years, whilst the glass of our windows and doors also answers the problem of how to maintain high thermal efficiency.

After you have taken a look through the following pages, please feel free to ask any questions you may have and we will be pleased to answer them. You can take a tour of our website, email us, give us a call or even arrange to visit our showroom and factory to see our products first-hand.



Sub Contents

6 **Balcony Systems curved patio door makes impressive statement**

Case study, David and Lynn Walton bring their garden into their home with impressively large curved patio doors in Nottinghamshire



8 **The perfect garden balustrade from Balcony Systems**

Case study, Iain and Jayne Twaddle's 29m balustrade at their self-build home near Newtown provides a low maintenance safety barrier whilst retaining views



10 **Juliet balconies, loft conversions and Balcony ideas**

Two case studies, Claire and Charlie Hodgson's Juliet balcony at their London home and David Webster's home on the Isle of Islay shows off a cleverly styled balcony to a loft conversion



12 **Balcony Systems' products fully exploit Isle of Man views**

Case study, Philip and Jillian Routledge's Isle of Man guest house takes advantage of fantastic views through curved, sliding patio doors and clear glass balustrading



14 **See how Balcony helped create a perfect balustrade for Welsh Coast House**

Case study, Keith and Chad Young's Fishguard home uses a 12m balcony and 10mm glass to retain its expansive views



16 **Three-climate views from one beautiful balcony**

Case study, John Sharp self installs a 17m curved and straight glass balustrade at his East Ayrshire home





Balcony Systems curved patio door makes impressive statement

At nearly 10 metres wide, David and Lynn Walton's curved patio door with four fixed and four sliding panels makes a truly impressive statement at their Nottinghamshire home. It also amply demonstrates the spectacular appeal of the product.

"It certainly achieves what we wanted; that is to make the most of views to the garden and we have brought the garden into our home," said David. "The door is a focal point in the living room where it forms an entire wall at one end. It's so striking and everyone likes it!"

"Now we have fitted the decking the curved patio door really comes into its own. It is never too hot or too sunny and the pleasure of the panoramic view of the garden cannot be over emphasised."

"The door is so dramatic and there really is nothing quite like it on the UK market."



The door, finished with a RAL 7038 Grey powder coating, was installed as part of extensive renovations to the 300-year-old property, which now incorporates three former farmworkers' cottages into one.

Measuring 9.81m by 2m, the door forms a circular glass 'wall' flooding the living room extension with light. Directly above is a bedroom topped with an Oast House-effect pointed roof with glass apex that casts light into the room below.

The circular shape was originally designed with oak uprights, but the plans changed once the couple saw Balcony's curved patio door at the Grand Designs show and that sealed the deal for them.

"The price was right - and quite competitive - for what is a totally bespoke job,"



"The price was right - and quite competitive - for what is a totally bespoke job," added David. "The door is so dramatic and there really is nothing quite like it on the UK market."

"Having overcome some challenges with this project, the end product is perfect and looks fabulous."

The perfect garden balustrade from Balcony Systems

It's a case of 'mission accomplished' for a mid-Wales couple whose clear glass balustrade supplied by Balcony Systems has created the ideal safety solution for their elevated patio area while preserving far-reaching views across open countryside.

Not only does the 29 metre glass balustrade with Balcony's proprietary Royal Chrome anodised handrail provide a low-maintenance safety barrier, it also adds the finishing touch at Iain and Jayne Twaddle's rural self-build home near Newtown – much to their delight.

"Our sloping site presented quite a challenge. We needed to build a stone wall to create a flat patio area with a conservatory," said Jayne. "Then we needed something to go on top of the wall that didn't destroy the country views and provided the required safety - there's a drop of more than 1.5m from the top of the wall down!"

"The glass balcony was the perfect boundary to put on top of the wall which finishes under our patio area. It needed to be safe and, most importantly, not spoil the splendid views – we believe we succeeded in our mission!"

Having found Balcony Systems on the internet, the couple decided to visit their Lingfield showroom and see the products for themselves. "Originally we had planned to use stone posts and rails but changed our minds once we discovered Balcony Systems," explained Iain.

"We arranged to visit Balcony as we wanted to examine the strength of the balustrade first-hand and see how it was fixed. Everyone was extremely helpful and answered all our questions. Their advice

***"The glass balcony was the perfect boundary
It needed to be safe and most importantly,
not spoil the splendid views – we
believe we succeeded in
our mission!"***

was spot-on and technical support has been marvellous as well."

The couple's visit also proved helpful for their installation team as they could pass on the shared information to them. "Our builders, Davies, Roberts and Bowen,



had not done anything like this before, so they watched the Balcony videos and read the material before starting.

"Once they got over the typical traditional builder question of 'where's the corner post?' (there isn't one!) they got on with the job with ease and enjoyed installing the quality product. I would recommend them for any Mid-Wales/ Borders installation."

The couple had specified Balcony's BalcoNano® self-cleaning glass coating on the panels, which dramatically reduces cleaning cycles. This durable protective coating covers the microscopically-pitted surface of glass, making it smooth and

water-repellent. Dirt and other deposits cannot cling to the glass surface and either washes away easily or is simply cleaned with water and a cloth.

"As there is a large expanse of glass and being surrounded by fields and lots of farming activities, we felt it would be a good idea," said Iain. "And yes, it's keeping cleaner. We're also impressed with the really good quality handrail – straight and so smooth."

In conclusion, Jayne and Iain added: "We are really pleased with our Balcony balustrade. It has worked out as a good solution. The effect has been to create a homely border to our property – we love it!"

Juliet balconies, loft conversions and balcony ideas

To be barred, or not to be barred? That is the balustrading question facing homeowners installing French Doors at high level or in loft conversions. Effi Wolff, Managing Director of Balcony Systems, discusses the clear solution.

Whether 'tis better to suffer the on-going maintenance of metal railings or to enjoy the clear views from a low-maintenance glazed version?

This decision is now much easier for homeowners undertaking installation of upper floor full height glazing or conversions of their lofts and roof spaces to add value, space and light to their homes or to avoid the expense and hassle of moving.

According to a recent survey by the Nationwide Building Society, adding both a bedroom and bathroom through extensions or loft conversions, in London or anywhere across the UK, can add up to 23% to a property's value. So it's also an excellent investment.

Space permitting, many projects incorporate French Doors to increase natural light and enhance the feeling of spaciousness within these newly-created rooms. At first or second-floor levels, a balustrade is a Building Regulation requirement to provide the required safety barrier when the inward-opening doors are open.

In this case, the glass Juliet balcony takes centre stage as the preferred balustrading solution for French Doors in converted roof spaces. Easy to install, with no obstructions to natural light or the

views outside, the aluminium handrail and glass panels require virtually no expensive and time-consuming maintenance to keep it looking as good as new.

From the outside, the result is just as aesthetically pleasing with elegant clean lines lending a contemporary appearance to any property. Adding a glass Juliet balcony is the all-important finishing touch.

As an affordable and versatile solution for loft projects, glass balustrading offers other design possibilities, such as protecting the stair access allowing greater penetration of natural light to the stairwell.

Bromley-based Spencer Clifford, Director of Loft Life, comments: "French Doors in loft conversions certainly let in a lot more light compared to the traditional dormer window, which, arguably, is not as attractive a feature. It's quite a startling trend but it makes sense from a resale point of view. There's a big difference between a conventional plain window and French Doors with an attractive glass balcony that allow light to flood the interior."

Located in 'the heart of loft conversion land', Spencer estimates around three-quarters - or 16 out of 20 loft conversion projects - involve French Doors rising to around 9 out of 10 in parts of South West London.

"It looks incredibly smart and shows off our new loft conversion to its greatest potential."

For London residents Claire and Charlie Hodgson, whose major home extension project featured on Channel 4's Double Your House for Half the Money with Sarah Beeny, a glass Juliet balcony was the obvious choice.

Claire says: "It looks incredibly smart and shows off our new loft conversion to its greatest potential. Our new main loft bedroom is pretty special and having Balcony's glass Juliet balcony really finishes the conversion off to an extremely high standard. It looks fantastic and we are absolutely thrilled!"



“... all the components arrived on time and perfectly packaged,” added David.

“The balcony was easy to install over a weekend and the glass really complements the Velux windows.

I’m very pleased...”



For recently retired David Webster, the clever shape of the balcony adds the finishing touch to his three-bedroomed, traditionally-styled property set on a quarter-acre plot next to the Bruichladdich Distillery on the malt whisky island of Islay.

“Two years ago, the site was a marshy, boggy field; but now the house is complete and the balcony is a real

feature that was well worth doing,” explained Glasgow-based Dave, who eventually might move permanently to the island.

A key aspect of his ‘retirement project’ is the light interior to the first-floor master bedroom from the three vertical and sloping Velux windows. One window opens out to provide access to the balcony.



“The basic plan was to have metal railings, but I thought I can do better than that. I didn’t want to spoil the view with bars. So when an internet search revealed Balcony Systems and their range of glass balconies, my decision was clear,” continued Dave, a DIY enthusiast.

However, the shape of the Velux windows called for an ingenious solution, devised by Balcony Systems, to secure the anodised aluminium handrail to the roof by drilling through the slates to the roof timbers. The result is a completely hidden fixing above the two 45-degree triangular glass side panels.

“Balcony devised the really bespoke solution for the handrail and all the components arrived on time and perfectly packaged,” added David. “The balcony was easy to install over a weekend and the glass really complements the Velux windows. I’m very pleased, it looks great and the 45-degree brackets were perfect. Thanks for a great service!”

Standard Juliet Systems

Balcony Systems offer an incredible range of three Juliet balcony systems offering 80 different standard models available with a 5 working day turnaround.

The Traditional Juliet System

Balcony Systems’ Traditional Juliet balcony type utilises a 70mm diameter handrail and a bracketed bottom rail that fits underneath the sill. It is available in seven standard sizes from 1.28m to 2.84m wide or in custom sizes up to 3.26m wide.

The Aerofoil handrail Juliet System

Using Balcony Systems’ unique BAL 2 handrail with the aerofoil shape and a bracketed bottom rail that fits underneath the sill, Juliet balconies of up to 4.10m in width can be achieved without any posts. This system is available in seven standard sizes from 1.28m to 2.84m wide or in custom sizes up to an amazing 4.10m handrail width.

The Mirror Juliet System

Named the “Mirror” Juliet because the circular handrail is mirrored top and bottom. The advantages of this system are the fact that it avoids requiring fixing underneath the sill. Limited to a maximum width of 2.45m it is available in six standard sizes from 1.28m to 2.45m wide, or can be custom made up to the limit of 2.45m width.

All systems are available with four handrail colour options - white powder coated, silver, bronze and Balcony’s proprietary Royal Chrome anodised finish. You can also choose different glass options as well as the BalcoNano® self-cleaning coating. Find out more technical details on pages 36-38.

Balcony Systems' products fully exploit Isle of Man views

Fantastic panoramic views of the southern tip of the Isle of Man from a luxurious bed and breakfast property are fully exploited using every product from Balcony Systems' wide range of low-maintenance clear glass balustrading, Juliets and curved sliding patio doors.



Owners Philip and Jillian Routledge specified Balcony's four-panel curved patio door, with two sliding panels, that forms the stunning centrepiece of the domed guest lounge at The Arches overlooking Port Erin. Either side of the curved white aluminium powder-coated doors are two further straight patio doors allowing additional access to the outside space.

Forming a semi-circle that measures 8.4m in girth and maximising the 180-degree views, the curved door has 28mm Low-E toughened double

glazed units. It opens onto a square terrace with a frameless structural glazed balustrade, also supplied by Balcony Systems. This balustrading style was chosen specifically to fulfil safety requirements with low-maintenance minimum visual impact, plus the added benefit of protection from prevailing winds.

The curved patio doors and balustrading elements were installed by Chris Wedgwood, Managing Director of Jurby-based Hamilton Project Management Ltd and incorporated as

part of extensive remodelling to the substantial 1920s building, perched on a steep site in Tower Road.

Five years of construction work included rebuilding and extending the southern elevation and roofing over what was an outdoor swimming pool.

Following the shape of a second lower terrace next to the swimming pool are nearly 40 metres of Balcony's curved and straight balustrading, topped with Balcony's proprietary Royal Chrome anodised handrail. Above this terrace, three glass Juliet

“It’s so central to what we wanted to achieve. There’s no product like it and it really brings the outside in!”

balconies supplied by Balcony Systems maintain clear views from guest rooms on two upper floors.

Having holidayed on the Isle of Man for many years, the couple moved there from the UK in 2006 having fallen in love with The Arches’ spectacular coastal location. The B&B opened for business in 2011.

Philip, from Liverpool, explained: “The incredible views inspired all the glass as the whole point was to maximise the pleasure from them. It’s unusual to have 180 degrees of such splendour – and the

curved patio door from Balcony Systems really does it justice. Everyone is stunned when they see it and it adds so much to the value and enjoyment of the property.

He added: “As the house is located near to the sea, that’s great for the views but a real challenge to the materials used to enable us to enjoy them to the full. After four or five years of installation, the finishes on our Balcony products are like new.

“The curved patio door performs well; it’s thermally-efficient, air and watertight,



even during the wild weather we get sometimes. It’s so central to what we wanted to achieve. There’s no product like it and it really brings the outside in!”

Project architect John Cryer, of Marshall Cryer Architects said an initial triangular design for the lounge was adapted into a more space-efficient curve after consultation with Balcony Systems.

He said: “The curved door is a remarkable product, making the most of the space and views while turning an ordinary room into something much better. This site is so suited to this

product. So many sites on the island have good views that would benefit from products like those from Balcony Systems. I would definitely use their products again.”

According to Chris Wedgwood, it’s the combination of Balcony’s three different products that work really well at The Arches. “The curved patio door undoubtedly gives the house its ‘wow’ factor and makes the most of the views. The structural glass balustrade is a fantastic answer for uninterrupted views. They’re all good quality, well-thought out products.”

“The curved patio door performs well; it’s thermally-efficient, air and watertight, even during the wild weather we get sometimes.”



Perched on a steep slope overlooking Fishguard and the Irish Sea, the aptly-named Ty'r Arfordir 'Coast House' retains its expansive views with a clear glass balcony supplied by UK balustrading specialist Balcony Systems.

Keith and Chad Young specified the Balcony 1 system measuring more than 12 metres with 10mm clear toughened glass and handrail finished in RAL 7016 Anthracite Grey for their spectacularly-sited self-built home in far West Pembrokeshire.

After Keith retired from a career in air traffic control, the couple moved from Hampshire to buy the plot in Pembrokeshire where Chad had retained family connections and to realise their self-build dream. A glass balcony spanning the living area and master bedroom was top priority to keep the sweeping views.

"The Balcony Systems balcony is great value for money, very competitively-priced and the clear glass enhances the fantastic views, which was also very important," said Keith.

See how Balcony helped create a perfect balustrade for Welsh Coast House

“Being glass, the balcony is low-maintenance and complements perfectly our home’s modern, open-plan design, while also providing protection on windier days.”



“Another key factor in choosing Balcony Systems was their ability to supply the handrail RAL colour in the same shade as that used on the external trim of the house to ensure everything blended in. It matches the decking, roof materials and other glazing and looks fantastic!”

Balcony Systems’ efficient planning, design and delivery service also

impressed Keith, who added: “Being glass, the balcony is low-maintenance and complements perfectly our home’s modern, open-plan design, while also providing protection on windier days. It’s a delightful addition to our home and a great place from which to take in the superb views.”



“It’s a delightful addition to our home and a great place from which to take in the superb views.”



Three-climate views from one beautiful balcony

Self-installed by John Sharp, this stunning glass balcony supplied by Balcony Systems does full justice to fabulous south-facing views from his East Ayrshire bungalow.

"It's a technically competent design and what's great about the Balcony Systems' balustrade is that you can't see any fixings,"



“Delivery and service from Balcony Systems was absolutely first-class and I would recommend the company wholeheartedly.”

John, a retired valuation surveyor, found fitting the 17 metre-long curved and straight balustrade at his extensively renovated 1930s Newmilns property was a relatively straightforward job.

“It’s a technically competent design and what’s great about the Balcony Systems’ balustrade is that you can’t see any fixings,” continues John. “Once the posts were in position, the Chrome handrail fitted well and I am absolutely delighted with the result. The balcony is much admired – and the wow factor is a major part of it!”

Glass was essential to keep the far-reaching views over the Irvine Valley from the quarter-acre plot, with the added benefit of not needing any time-consuming painting or maintenance. “To have put a wooden balustrade would have been nuts!” I would not have wanted anything to disrupt the view,” he says.

John opted for a curved balcony, having changed his original rectangular concept as it had ‘no architectural feel whatsoever’. A former neighbour told him about Balcony Systems’, having installed one of their Juliet balconies on a similar property to his.

He explains: “Having seen the case studies on the website, I designed my balcony round the Balcony Systems’ products and asked my architect to send the drawings to them. This required overcoming major changes, including shaping the deck’s structural steel beam into a curve.”

John installed his balustrade gradually, enlisting the help of a friend to weld the

primary posts to the steel and timber joists of the cantilevered deck built onto the property. The straight and curved sections were easy to do, using just three lengths of handrail to cover the 17 metre length.

Measuring 3.0 metres wide at the centre point and 1.5 metres at each end, the balcony area provides a flexible area for entertaining and is accessed from two sets of sliding patio doors from the main living rooms as well as a set of stairs at one end.

Refurbishment of the former six-bedroomed bungalow included demolishing internal walls to create larger rooms and open-plan living areas, flooding the interior with light.

Design, ordering and logistics throughout the project progressed smoothly, according to John, who adds: “Delivery and service from Balcony Systems was absolutely first-class and I would recommend the company wholeheartedly. The quality is there to be seen and I’m confident the balcony will deliver what I want.”

As for their new balcony, John and his wife Kath, who downsized from a much larger property, are looking forward to enjoying what is undoubtedly a unique feature of their hillside home.

How? “With a bottle of wine enjoying watching the birds, clouds and constantly-changing scenery,” concludes John. “Here we can get three climates in one day – and a clear glass balcony provides the perfect vantage point from which to take it all in.”

Balcony Views Magazine welcomes new subscribers

With a circulation of 25,000, subscribing to Balcony Views Magazine is the best way to keep up-to-date with our new and innovative products and designs.

To receive your own copy of Balcony Views go to:

www.balconyviews.co.uk

or email:

sales@balconette.co.uk

or tel:

01342 410411

or write to:

**Balcony Systems Solutions Ltd
Unit 6 Systems House
Eastbourne Road
Blindley Heath
Surrey
RH7 6JP**

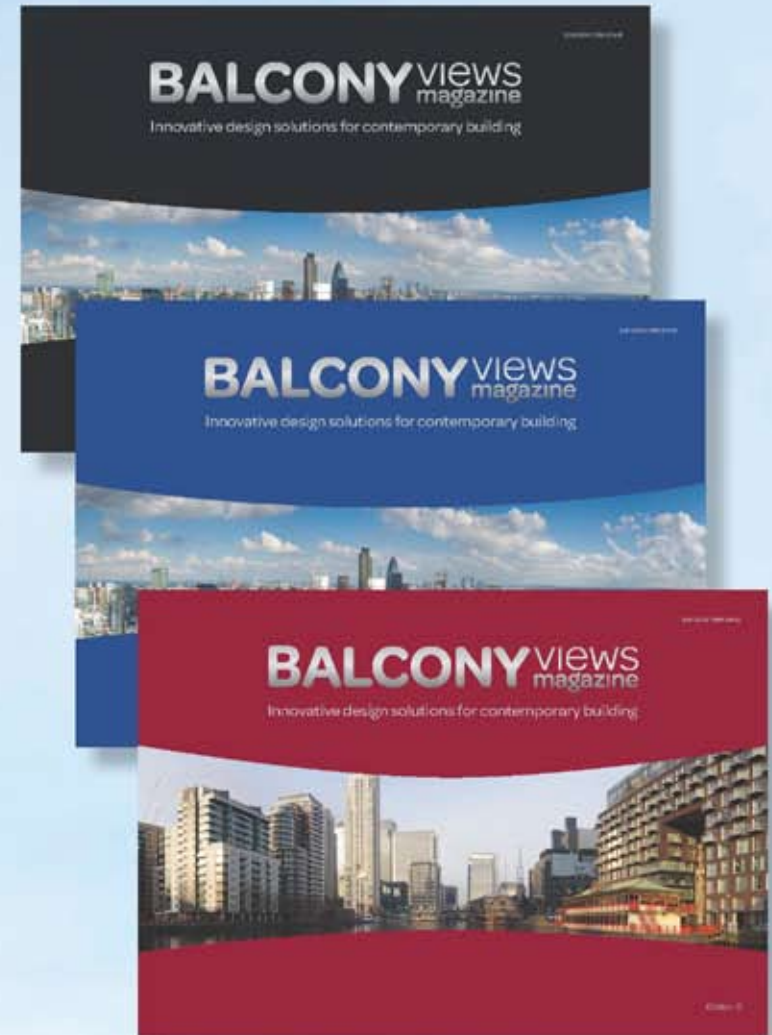

BALCONY views
magazine

What Balcony Systems offers house builders, contractors and property developers

Balcony Systems clear glass balconies, balustrades and patio doors provide a modern, eye-catching flourish that enhances the architecture of both residential and commercial developments.

Over the years we have established a well-deserved reputation not only in terms of the design options provided by our innovative materials but also of ongoing customer support, advice and the overcoming of technical problems. With this considerable experience and a first-class track record of working with developers, we are able to meet the specific requirements of projects of any scope or size and offer you materials and designs that overcome the problems associated with traditional materials such as stainless steel, iron and timber.

In doing so, we have shattered the concept of glass balustrades being cost-inhibitive. You will find that we combine a very good deal on the initial purchase together with a long-term cost-saving compared with traditional materials. Our products are made from materials that are resistant to corrosion and rot and save on painting and repairs, including our protective glass coatings.

Meeting your specific and unique requirements, we can provide you with custom-made or standard sizes, configurations and finishes. Installation is straightforward, with technical

questions answered promptly and quickly resolved.

A further important aspect, of course, is our ability to provide a snap-and-pop service with a short lead time and prompt delivery, plus on-site assistance with fitting and installation if required.

This is all backed up with full on-going technical support from start to finish in terms of programming and design, technical drawing, load tests, technical specifications, structural calculations and so forth.

A look at the many projects we have completed up and down the country will show the aesthetic contribution our products and service can make to the appeal of your finished project, while our customer testimonials will give you some idea of the thoroughness and dependability of our support.

Meanwhile, if you have any questions please tour our website or, better still, get in touch and we will be pleased to help. We welcome individual enquiries from installers, quantity surveyors, builders and developers and if you want to see our showroom, factory and our products first-hand we will be pleased to welcome you.

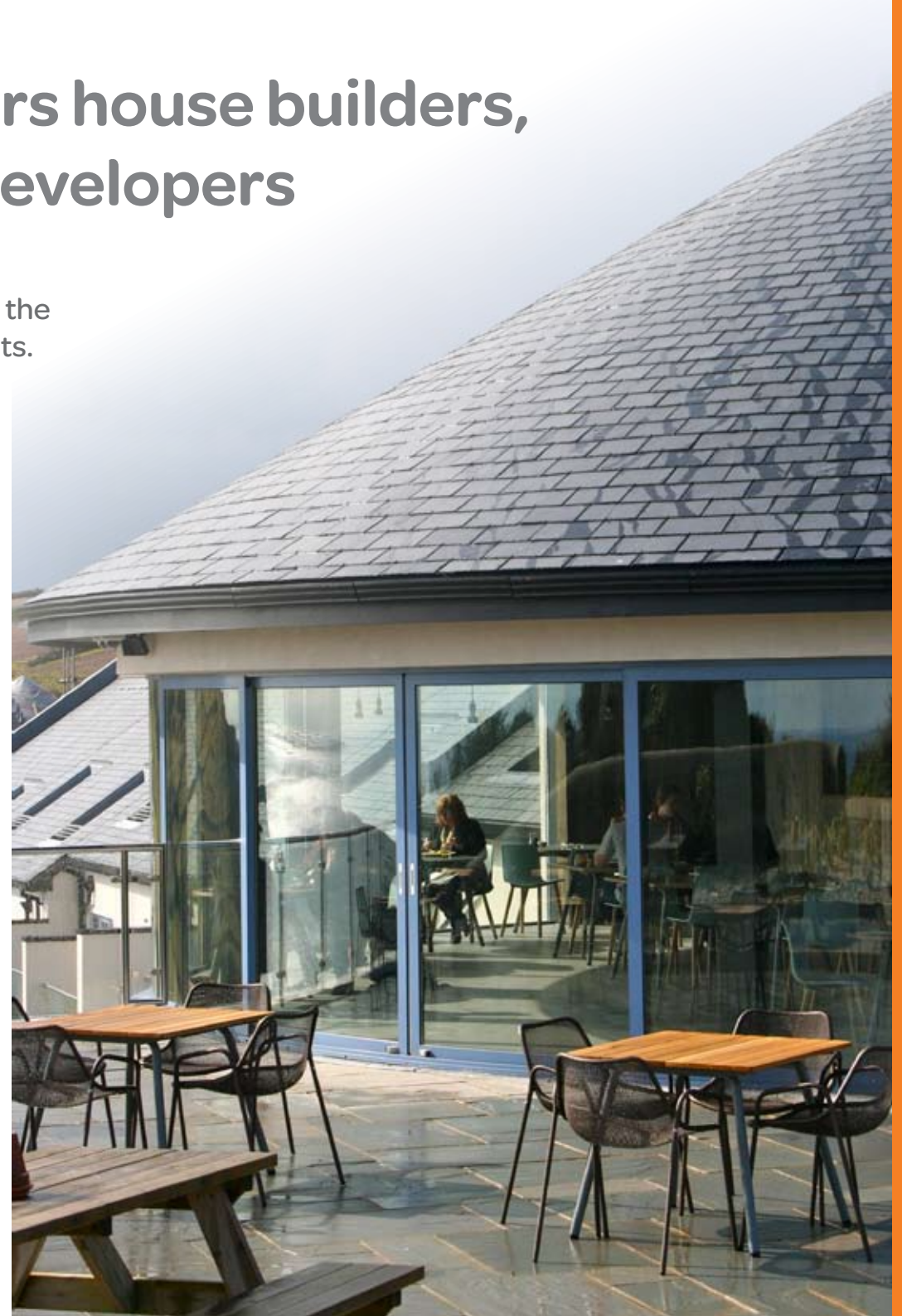



Sub Contents

21 **Balcony Systems – Working with developers, house builders and contractors**

How Balcony Systems develop relationships with companies from Aberdeen to the Channel Islands

24 **Balcony Systems delivers excellence for 377 balconies in London**

Case study, clear glass balconies are a striking architectural design feature of the landmark Baltimore Wharf development in London's docklands

27 **Glass Juliet balconies – what they can do for house builders**

Balcony Systems' glass Juliet balconies make an impact in Cambridgeshire, Denham, Lesmahagow and the Falkland Islands

30 **Stunning Balcony curved patio doors ignite interest**

Offering virtually limitless design possibilities curved patio doors are installed at a Devon resort and a striking Norfolk project

33 **Balconies in Bognor by the sea. Seven years on, how have they fared?**

Case study, built by private developer Hamlet Homes Ltd, we take a look at the longevity and robustness of 300m of glass balustrading using Balcony Systems' proprietary Royal Chrome finish.

Balcony Systems – working with developers, house builders and contractors

For house builders, the Balcony Systems' balustrading products offer many advantages in terms of cost-effectiveness, longevity, low-maintenance and aesthetics. Add in our ability to deliver on time, on budget and with technical support, they're just too good to resist!

More and more house builders, developers and specifiers are recognising the benefits of our glass balustrading and moving from traditional choices, such as higher-maintenance steel, timber or iron, to modern materials that provide long-term

savings on maintenance over their lifetimes. Balcony Systems works closely with developers involved in projects of all sizes across the UK. From large developments and new-build schemes to a single dwelling.

We would like to show some examples in this article of different projects in England, the Channel islands and in Scotland showcasing some spectacular results.



Cradley, near Malvern

We are always interested in developing long-term business relationships with house builders, contractors and developers and as the first example let us take IE Developments with whom we started working in 2006. We have worked on several projects together, and as outlined below, we would like to share some of our success together and show two of their key projects; the Cradley development, near Malvern and "The Point" development in Hereford.

According to IE Developments Managing Director Tim Evans, the simplicity, cost-effectiveness and clean lines of Balcony's design were key factors in their balustrading specification for their award-winning new 'eco' development on the Herefordshire/ Worcestershire border. External clear glass balconies off the bedrooms of five detached homes at St Katherine's Field, Cradley use the Balcony 2 system featuring Balcony's proprietary Royal Chrome anodised handrail.

The high-specification properties near Malvern incorporate the latest low-maintenance materials and energy-saving measures, from triple glazed windows to an intelligent heating and solar system. The development won the Housebuilder category of the Worcester Bosch Environment 2020 Awards 2013.

Tim commented: "The Balcony balustrading is well-designed, so easy to install and looks very good. It has the 'less is more' appearance, which we like and, of course, the need for minimal posts keeps uninterrupted clear views to the outside.

"The low-maintenance aspects of Balcony's system means no painting or repairs are required over the balustrading's lifetime, which fits in with our philosophy to deliver quality homes for discerning purchasers that offer the ability to 'lock and go' with confidence. We will be using Balcony Systems' products again on our next apartment scheme in Malvern."

Hereford

Balcony has also supplied balustrading for The Point, a luxury residential development of twelve apartments, two penthouses and two townhouses at Aylestone Hill in Hereford.

For Tim, the elegance and simplicity of the Balcony system perfectly matches the ethos behind the project's specification to offer a practical, stylish and high quality living environment with minimal maintenance requirements.

"The finesse and clean lines of the system made it the ideal choice to enhance the angular architecture of the development," he explained. "Unlike alternative glazed balustrading products, the Balcony system does not use corner posts or glass clamps that spoil the clear aesthetics. It is also very cost-effective.



"The finesse and clean lines of the system made it the ideal choice to enhance the angular architecture of the development,"



"Balcony also advised us on some of the technical aspects and the whole system was very straightforward to install.

From a developer's point of view, Tim highlights the significant advantage of fixing the glass panels from the inside. If a panel should need replacing in the future, this can be done easily and safely from the balcony itself, rather than hiring costly and time-consuming scaffolding or 'cherry pickers'.

He added: "The Balcony system addresses the long-term practicalities and maintenance issues to ensure compliance with the regulations, providing peace of mind for all from the outset. This is a real plus, as no one wants to go back to a job if things go wrong!"

Jersey, Channel islands

On the Channel Island of Jersey, curved and straight glass balconies supplied by Balcony Systems are the perfect solution for the prestigious award-winning Chateau Valeuse apartments overlooking St Brelade's Bay.

Pallot Windows, the island's Balcony Systems dealer, installed the versatile Balcony 1 system with a handrail in Royal Chrome finish at the striking Art Deco-inspired building which comprises 15, one to three bedroom luxury apartments.

Offering tremendous design options for larger external balconies and balustrading projects, the system's elegant aesthetics complement the building's 1930s streamlined architectural style.



Designed by Jersey-based Naish Waddington architects and built by AC Mauger Construction, Chateau Valeuse took third place in the 'Best Large-Scale Development' category at the 2011 Jersey Design Awards.

Clear glass balustrading was a key design element for Naish Waddington describing the strong semi-circular balconies as 'sculptural, dramatic and functional'. The horizontality of the South Elevation is emphasised by the continuation of these balconies which span towards the central element. Chateau Valeuse is a calm, refined, modernist building, set within a landscape that evokes its seaside setting.

Project Architect Bruno Francisco commented: "Balcony Systems was able to provide a cost-effective semi-frameless curved balustrading solution to ensure uninterrupted sea views. We were able to achieve this with semi-circular projecting balconies using the handrail as the structural tie without the need for vertical intermediate posts"

Managing Director of Balcony Systems, Effi Wolff said: "As this impressive project shows, curved or straight panels, or a combination of both, can deliver the architect's vision for an aesthetically-driven balustrading solution that is as visually stunning as it is practical."

In recent years, balconies have become an important and aesthetic aspect of domestic architecture, particularly for apartments where they deliver valuable extra outdoor space.

Increasingly, modern balcony styles now favour glazed balustrading systems, rather than railings, to retain panoramic views of surrounding scenery.



Aberdeen

At Glen Farm, Dyce in Aberdeen, Balcony's glass balustrades make the most of picturesque views across the River Don from the 36 luxury apartments. Built by Barratt Construction Ltd for developer Quality Street Residential Investments, the one and two-bed apartments feature a combination of Juliet balconies and balconies measuring up to 5.5 metres wide.

Project Architect Douglas Jack of the Holmes Partnership selected the cost-effective system for its clear glass aesthetics to keep the views and to complement the properties' contemporary exterior appearance.



"Using a glazed balustrading system maximises the views over the river and farmland, one of the primary features of the site," he explains. "Unlike railings, glass does not obscure the view and allows residents to take full advantage of their balconies' rural setting."

Balcony Systems delivers excellence for 377 balconies in London

Balcony Systems Solutions Ltd developed a custom glass balustrade solution for 377 balconies, realising the architect's original vision for this expansive project and in addition created an amazing £500,000 saving on the original design.



Clear glass balconies are a striking architectural design feature of the landmark Baltimore Wharf development in London's docklands.

Breathing new life into the former London Arena site, Baltimore Wharf is an exciting and ambitious £150 million mixed development comprising private and affordable housing, retail, leisure and community facilities. Designed by architects Skidmore, Owings and Merrill Inc., it is among several significant construction projects in the Docklands area being undertaken by international developer, Ballymore Group.

Phase One of the Baltimore Wharf development, which includes more than 600 apartments in five separate residential blocks, is constructed on the 6.8-acre former entertainment site which is across the water from Ballymore's 50-storey, neon-lit Pan Peninsula residential development.

As a key architectural feature of the buildings' external facades, the design and installation of the external balconies required a particularly considered – and inventive – approach.

Working closely with the architect, developer and steelwork contractor, Balcony Systems developed an elliptical handrail and bottom rail system that created a bespoke 21st century balustrade solution to suit the requirements of the multi-storey buildings and, just as importantly, the £3 million budget.

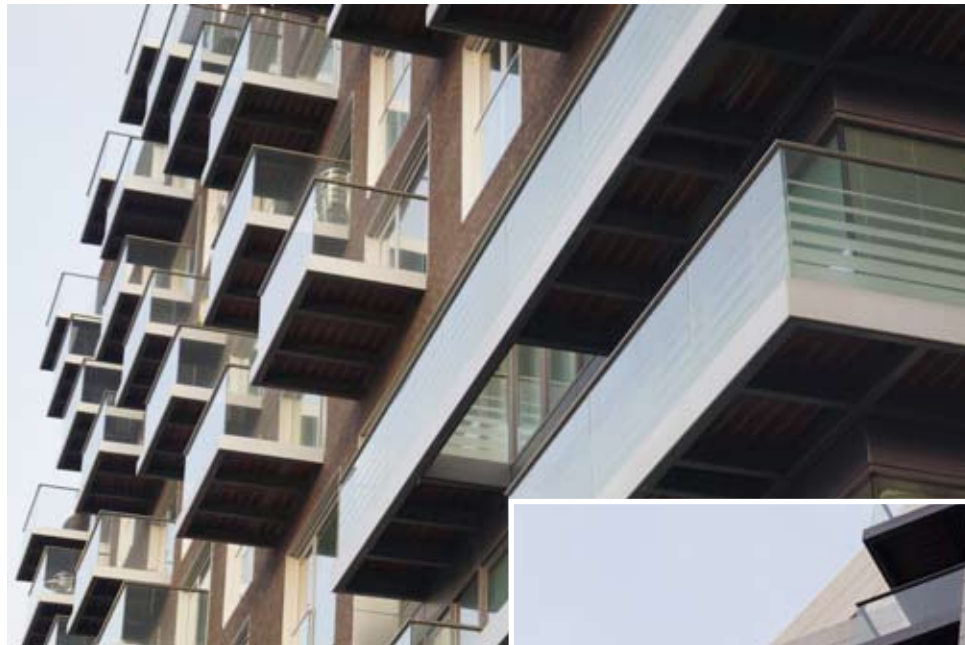

Balcony Systems also developed and supplied two unique extruded aluminium fascia profiles that finished off the edges of the balconies, one of them being a 295mm wide extrusion. The designed system enabled a balcony system solution which included frame cladding, decking and balustrade, delivered flat-packed, complete to site and ready to install.

The original design had called for a structural glass balustrade to be fitted on top of the steel balcony structure; this design required that the balcony steel be almost 300mm in depth.

Balcony Systems offered a design that allowed the balconies to be made with no vertical posts using a system that is smaller in height, lighter in weight, clearer in glass colour and one that created a saving of £500,000 from the original design.

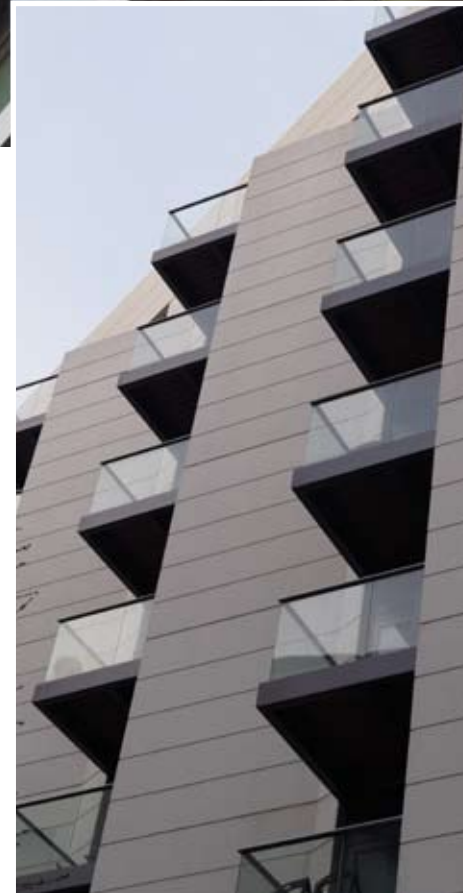

“Balcony Systems’ experience and ability to design new sections and adapt them to specific projects opens up a large expanse of design possibilities that can be realised”

The hand-railing was designed to take the load to provide all the required strength and support and meet all the relevant Building Regulations. Utilising the handrail allowed the balustrade to span the required lengths without the need for vertical posts.

According to Effi Wolff, Managing Director at Balcony Systems Solutions Ltd, the ability to meet the architect's original balcony design criteria - to present a perfectly flat front fascia to seamlessly fit the main steel and the glazing track - was of fundamental importance. A new aluminium handrail, finished in Royal Chrome to look like shiny stainless steel, and lower track extrusion was specially designed for the Baltimore Wharf apartments. This allowed for relatively simple fitting to the main steelwork.

“Balcony Systems offered a design requiring no vertical posts, was lighter in weight, clearer in glass colour and created a saving of £500,000 from the original design”



Cost engineering through innovation

As well as supplying 377 balconies for the project, a cost effective design was realised for the social housing area of the development, replacing the wrought iron original design with a glass balustrade that matched the budget.

In conclusion, Effi says: “Balcony Systems’ experience and ability to design new sections and adapt them to specific projects opens up a large expanse of design possibilities that can be realised. We like to get involved at the outset and can help drive the design to a meet the requirements by being innovative and budget aware.”

Whether made of stone, wood or cast iron and now glass, balconies are an enduring and popular building feature that has been with us for centuries. Their design has continued to evolve to meet the changing face of architecture. The Baltimore Wharf project represents another step forward in the evolution of balcony design, taking it firmly into the 21st century.

Feature fascia

“Clear structural glass was originally specified. However, our solution using toughened and laminated 9.5mm glass to retain a clear view without the need for posts and at a very competitive price satisfied the key requirements for this prestigious project,” he says.

“What is new about the system is that Balcony Systems has provided a flush-fitting anodised extruded aluminium feature fascia which provides a detail to

match the main buildings’ window frames. This hides the steel balcony supports presenting a neat front face to the structure.”

Effi suggests that what has made the design concept such a success was ‘going the extra mile’ to ensure that the original vision of the architect was maintained during the design period.

This was achieved through close collaboration with the architect, developer and steelwork contractor

from the early planning stages to meet the challenges of making the design work with no posts and to keep the structure down to a minimum. Measuring 3 metres x 2 metres and 2.3 metres x 2 metres, the balconies did not require any posts.

An added advantage of the system - particularly for high-rise buildings - is that panel replacement, if needed, can be done quickly and safely from inside. Panels are supplied up to 1.2 metre in length for ease of transportation and installation.

Glass Juliet balconies – what they can do for house builders

Shattering the concept that ‘glass is expensive’

For house builders and developers, installing low-maintenance glass and aluminium Juliet balconies instantly solves many of the problems associated with ‘traditional’ material choices such as stainless steel, iron or timber.

Firstly, cost saving is a major factor. Glass Juliet balconies are not only a great deal on initial purchase, but also prove to be a long-term cost-effective choice when compared to conventional balustrading materials as their corrosion

resistance means they don’t rust or rot. You can forget the need for on-going time-consuming painting or repairs.

Balcony Systems’ Glass Juliet balconies are probably the most cost effective products for this specialist market. Breaking the concept that glass balconies are expensive, Balcony’s range of Glass Juliets start from £175.

The minimalist appearance and clear glass that retains views and allows maximum light inside adds to kerb appeal, attracting purchasers and helping developers to sell more easily, especially to discerning buyers.

With more building professionals choosing the low-maintenance, high-aesthetics balustrading route, it may be of some benefit to read about some examples showing how these Juliet balconies have made an impact and worked on the following residential and commercial projects.

March, Cambridgeshire

Architect Chris Cooper of James Developments Company Ltd specified 78 Juliet balconies to enhance the riverside views of 18 exclusive townhouses overlooking the River Nene at March, Cambridgeshire.

Double-sized Juliet balconies are a distinctive feature of the three and four-bed Sandpiper houses, maximising the properties’ light, space and views overlooking private moorings and increasing the appeal of their rural location.

Each of the mid-terraced homes has a total of four Juliets, measuring 1.7 to 2.9 metres wide, with end properties benefiting from an extra set on their side elevations.



“It’s a straightforward product for a straightforward situation...”

Commenting on the use of the Balcony system, Chris said: “Key criteria for us was something light in appearance and it had to be completely ‘kiddie-proof’. For example, the balustrading could not be climbed over, nor trap a child’s head. Added to which, the system had to be reasonably priced and fully finished.

“Installation was simple. It’s a straightforward product for a straightforward situation and it has been well-received by purchasers,” continued Chris.

He added: “We are seeing more and more Juliet balconies as ‘standard’ features because as well as being a useful marketing tool, they are attractive and very popular with buyers. In a riverside setting, such as the Sandpiper properties, they give the sense of being on a deck, while at the same time maintaining privacy.”

Balcony’s Managing Director Effi Wolff said “designers have welcomed a low-maintenance system that is not only simple to install, but allows greater freedom of design options.” He added: “Straight or curved glass can be used to create elegant Juliet and external balconies without the need for vertical or corner posts.

“Increasingly, architects are seeking an attractive balustrading solution that combines safety with maximising light and spaciousness, but at reasonable cost. The Balcony system does just that.”



King’s Island in Denham

In a large prestigious gated island development at King’s Island in Denham, near London, 180 Juliet balconies in a mix of standard and bespoke sizes were specified for five new apartment blocks by developer Weston Homes.

All the Juliet balconies use Balcony’s eco-friendly BalcoNano® double-sided self-cleaning glass coating to keep the glass looking cleaner for longer, greatly reducing cleaning cycles by up to 90%.

The four-storey buildings, completed in 2012, overlook the Grand Union Canal and River Colne on the site of the former William King Flour mill close to the M40 and M25.

The balconies were supplied with a Royal Chrome handrail, which replicates the look of stainless steel, and installed by contractors Quality Metalwork Services Ltd on the new buildings and converted original flour mill.

Commenting on the project, QMS Director Adrian Leach says: “It is the first time we have worked with Balcony Systems and their service and delivery were excellent, enabling us to complete phased installations within exacting time schedules. The Juliet balconies were very

straightforward to fit and took just 1.5 hours for each one.”

Balcony Systems supplies many of the UK’s major house builders. Introducing the self-cleaning glass coating option has further increased the products’ appeal.

“We are seeing continuing demand for our low-maintenance, competitively-priced products from house builders of all sizes,” commented Effi. “Our BalcoNano® self-cleaning glass coating is now an almost universal client choice.”

Balcony Systems’ Juliet balconies also deliver great results for bespoke refurbishment projects. Castleoak, a leading care sector development and construction company, specified clear glass Juliet balconies for one of its care projects to make the most of magnificent lakeside views in South Lanarkshire.





“Working with Balcony Systems was straightforward. All of the technical questions were quickly answered and telephone calls returned immediately.”

providers. The project also involved the refurbishment of the previous atrium area into a communal lounge and four premium apartments on the second floor.

Castleoak Project Surveyor Sean Coyle said the Balcony Systems’ product was chosen as it matched the architect’s design and allowed light into the property, whilst retaining unrestricted views across the lake and landscaped grounds.

He commented: “The Juliet balcony system worked on our building extremely well.

Auchlochan was the first project where we used the Balcony Systems product and after Balcony provided a quotation during the estimating process, it was a natural progression to follow this through to an order.”

Sean added: “Working with Balcony Systems was straightforward. All of the technical questions were quickly answered and telephone calls returned immediately.”

Lesmahagow, Scotland

Balcony’s product met the architect’s precise balustrading specification for French Doors in 20 remodelled extra care apartments at The Retreat, Auchlochan Retirement Village near Lesmahagow, south of Glasgow.

It is the first time Balcony Systems had worked with Castleoak, whose project in Scotland was its thirteenth for MHA, one of the UK’s leading not-for-profit care

Stanley, Falkland Islands

In what is one of its remotest projects to date, Balcony Systems has supplied glass Juliet balconies to The Waterfront Hotel in Stanley, capital of the Falkland Islands.

The bespoke balconies were shipped to the islands, which lie eight thousand miles from the UK in the South Atlantic Ocean.

Each one measures 2,775mm wide and features Balcony’s proprietary Royal Chrome handrail. They were installed in front of patio doors in the boutique hotel’s restaurant overlooking the harbour, as part of refurbishment works at the eight-bedroomed hotel.

Luis Romo of The Falkland Islands Company Ltd, who placed the order, explained: “Balcony Systems was the only company to give us a quote and the only one which took any interest in supplying us with the product.

“All the logistics were taken care of by our UK office and we were very pleased

with the service from Balcony Systems. The balconies were installed in early January 2014, arriving three months by ship after placing the order.”

The owner of the hotel, Alex Olmedo specified a glass balcony to give an unobstructed view of Stanley harbour as well as to provide an aesthetically-pleasing secure barrier when the doors are open.

He said: “We’re very impressed with the final results and have achieved the modern and commercial look we were after. The building now looks stunning.”

Effi Wolff, Balcony Systems Managing Director added: “We supply our products worldwide, but the Falkland Islands is probably the furthest place so far. As our products are made from corrosion-resistant materials, they are ideal for coastal climates. We were delighted to help and hope the hotel staff and their guests derive many years of enjoying the views from their Juliet balconies.”





Stunning Balcony curved patio doors ignite interest

For specifiers, house builders and developers, Balcony Systems' curved sliding patio doors offer unrivalled innovative and interesting solutions. Combining panoramic views with enhanced light to the interior, curved doors add a dramatic new perspective to any building.

What they bring to properties in terms of sheer impact, practical appeal and aesthetics is hard to equal. Balcony's expertise in bending and curving glass has enabled us to develop an affordable curved sliding door option that is as versatile as it is stunningly beautiful.

Offering virtually limitless design possibilities, the system allows for a variety of configurations from two curved sliding doors up to six door panels that open up approximately two thirds of the aperture.

Using thermally-broken aluminium profiles together with Low-E curved

double glazing, the doors save on heating costs as well as complying with current trends and regulations. All doors come with multi-point locks for additional security.

Since introducing these unique doors to the marketplace, Balcony has worked with architects across the UK, Europe and beyond to bring their creative design concepts to fruition. The following are some of Balcony's exceptional curved door installations that genuinely add the 'WOW' factor to both residential and commercial projects.

Show-stopping curved door at Devon Resort

A show-stopping curved sliding patio door dishes up panoramic ocean views every day for diners at the Gara Rock Restaurant, part of an exclusive coastal resort complex built by Coast Group near Salcombe in South Devon.

Measuring nearly 15 metres in width with a blue powder-coated finish, the door opens onto an outdoor dining terrace. The nine-panel door incorporates two sliding panels and spans well over half the building's circular sea-facing elevation.

Directly below, a second eight metre-wide curved patio door with two sliding panels, also supplied by Balcony, offers similar spectacular sea views for guests using the indoor

swimming pool and spa facilities.

Diana Hunt, who runs the restaurant with Ian Dent, comments: "The wonderful curved glass wall and doors frame an almost 180 degree view of the South Devon coastline. We can open the curved glass doors back to the point where they almost seem to disappear. They are incredibly smooth, but heavy enough to dissuade children from playing too enthusiastically with them!"

The doors' versatility allows for a variety of sliding or fixed configurations, providing almost limitless creative scope for designers and architects. Wide openings can be achieved to seamlessly connect



"The doors enable guests to enjoy the beautiful views in comfort, whatever the weather, while also providing practical and easy access to the terraces by the restaurant and pool."

interior and outdoor spaces. Adding additional fixed curved panels allows for longer glazed runs, further enhancing views, light and the feeling of space to any interior.

Simon Baldwin, Director of Aminghurst Ltd, Gara Rock's owners, says: "Both doors are quite stunning, creating a distinctive visual statement and making the most of impressive vistas from the building.

"The doors enable guests to enjoy the beautiful views in comfort, whatever the weather, while also providing practical and easy access to the terraces by the

restaurant and pool."

Installation of both doors went smoothly, according to Gara Rock Site Manager Tim Jones, who adds: "The general consensus from everyone who sees them is that they look spectacular and really make the most of this unique cliff top location."

Built in 1847 as a former coastguard station and lookout, the buildings were converted into a family hotel in the early 1900s and became established as a popular holiday resort which has attracted some notable guests.

Requisitioned by the RAF during the Second World War, the hotel reopened but was finally closed in 2006 when work began on replacing it with the new Gara Rock facilities.

A Striking Norfolk Project

Light floods into the pool room through a six-panel curved patio door at this impressive bespoke dwelling set in 11.5 acres of Norfolk countryside. Measuring eight metres across, the curved door makes a striking statement on this multi-million pound, five-bedroom home with its distinctive curving roof structure. It's practical too, with four sliding panels that create a two-thirds opening aperture to connect the inside with the patio area outside.

Balcony also supplied more than 20 metres of straight balustrading, plus 15 metres of curved balustrading above the indoor swimming pool, which overlooks



the garden. All the handrails feature Balcony's proprietary stainless steel-effect Royal Chrome anodised finish.

In the conservatory, two made-to-measure Juliet balconies have been installed on straight eight metre-wide patio doors overlooking the pool below to provide the necessary security. On the front elevation, Balcony also supplied and installed a three-metre curved, glazed foyer entrance with the aluminium frames powder-coated in a dark green RAL 6016 finish.

Two further straight external glass balconies provide additional outdoor space while keeping clear views to the grounds from the master bedroom and a first-floor office.

David Groucott, Director of Suffolk based developers Encompass Project Management Ltd, selected Balcony Systems for their ability to deliver the required glazed elements meeting the demands of the building's unusual and contemporary design.

He said: "Not only do the Balcony products work extremely well on this

highly-individual property, they also deliver the required design criteria very cost-effectively making them excellent value for money. The curved patio doors from the pool room, in particular, make a statement that adds to the overall impact and enjoyment of living in this home for the client and his family."

Louise Knight of LSI Architects commented: "It's the first time we had worked with Balcony Systems and they delivered to the required timescales as well as producing additional items, such as extra handrails, at the client's request. This is a project to be proud of and we will include them in future quotations."

Completed in 2012, the new property replaced an original 1940s house on the site and took two years to build. It was developed on sustainable design principles to achieve Code for Sustainable Homes Level 4 and incorporates a ground source heating system to provide heating and hot water for the building and pool.



Balconies in Bognor by the sea. Seven years on, how have they fared?

The proof is in the pudding as they say ...



"Its 'good as new' appearance is in stark contrast to a stainless steel balustrade on another development at the other end of the seafront which has not fared as well and is starting to rust."

Constructed in 2007 and fronting directly onto the Bognor Regis seafront, the five-storey Compass Point building comprises 24 luxury two-bedroom apartments, each with its own large balcony or terrace to make the most of spectacular sea views.

The balconies are enhanced by distinctive curved steels, a design feature that 'connects with the sea', complementing the contours of the eye-catching corner tower. This tower also houses the living rooms of five of the homes and the master bedroom of the two-storey penthouse apartment with its sweeping curved balustrading.

Balcony Systems supplied more than 300 metres of curved and straight glass balustrading featuring their proprietary Royal Chrome handrail finish for the distinctive property, built by private developer Hamlet Homes Ltd.

Hamlet Homes specified the durable anodised aluminium Royal Chrome finish – specially developed by Balcony Systems – for its corrosion resistance and virtually maintenance free characteristics.

Almost identical in appearance to polished stainless steel but with none of the drawbacks, the Royal Chrome handrail is an ideal choice for coastal climates. Balcony introduced this special finish following clients' requests for a long-life product with the smart look of stainless steel.

“We were impressed by their products which are very cost-effective. They are also designed for long-term performance as amply demonstrated after seven years at Compass Point.”

Superior to stainless steel

Mike Neale, Estimator and Buyer at Hamlet Homes, stated: “Seven years on, the balustrading with the Royal Chrome handrail supplied by Balcony Systems still looks very good. It has certainly demonstrated its robustness and longevity in a testing marine environment.

“Its ‘good as new’ appearance is in stark contrast to a stainless steel balustrade on another development at the other end of the seafront which has not fared as well and is starting to rust.”

Mike continued: “We were originally going to use stainless steel balustrading but decided on Balcony Systems after their curved patio doors and balustrading caught my eye while researching them on the internet. The curved balcony on the penthouse apartment really adds to the flowing lines of the building.

“We were impressed by their products which are very cost-effective. They are also designed for long-term performance as amply demonstrated after seven years at Compass Point.”

Since 2007, Hamlet Homes has used Balcony’s products on several

other projects with great success.

Mike added: “The fact that the Royal Chrome handrail still looks great on a seaside property after seven years is a testament to the product’s durability and quality. We would recommend Balcony Systems and use their products again in the future.”



Balcony Systems technical details

We understand that you have to be certain of any products you incorporate into your design and that you need to be confident of them, not just in terms of their ability to provide the right aesthetic but also of their technical compatibility and structural capabilities and whether they offer sufficient flexibility so that they can be tailored to your specific design requirements.

With all that in mind, Balcony Systems Solutions provides customers, architects and specifiers an open library of information on all aspects of our products.

We couple our considerable experience of working with architects and developers on projects large and small, with state-of-the-art innovations in materials that provide a greater range of possibilities for incorporating the grace and light of clear glass into your designs. This enables you to explore an enhanced flexibility of options as practicalities of structure and construction rise to the challenges provided by the sweep of your imagination.

Overcoming many of the limitations presented by traditional materials such as stainless steel, iron and timber, our materials are also more resistant to corrosion or rot and require less in terms of maintenance, painting and cleaning, whilst our glass can be supplied with our unique protective coating for longevity and low maintenance.

We ally all this to a thorough technical department providing support and technical advice on matters relating to design, dimensions, configurations, calculations of loads and stresses and so forth, with prompt answers to questions you may have. A friendly advisor is never more than a phone call away.

It is not possible to include all the details within this format and so the following pages will show some of the standard technical details and specifications of the main product range. All technical details are available in electronic format either PDFs or DWGs.

A tour of our website will provide you with more information but we are always pleased to answer your questions by phone or even to arrange a visit to our showroom and factory so that you can familiarise yourself with our products and materials first-hand.

Sub contents

36 Juliet balconies

Traditional Juliet Balcony System
Balcony 2 System
(aerofoil handrail) Juliet
Mirror Juliet Balcony System



39 Balustrades

Balcony 1 Balustrade System
Balcony 2 Balustrade System
SG10 Semi Frameless System
SG10 Fully Frameless System



43 Curved doors

Curved Door Model W2F
Curved Door Model W3F
Curved Door Model W4F
Curved Door Model W6F



Technical details - Traditional Juliet Balcony System



Standard sizes available

- 1280mm handrail width
- 1500mm handrail width
- 1680mm handrail width
- 1860mm handrail width
- 2180mm handrail width
- 2450mm handrail width
- 2840mm handrail width

Custom sizes available

- Min 800mm handrail width
- Max 3260mm handrail width

Glass options

Standard models

- 10mm clear toughened

Custom models

- 10mm clear toughened
- 10mm green toughened
- 10mm grey toughened
- 10mm bronze toughened
- 10mm blue toughened
- 10mm satin (opaque) toughened

Optional extra (for all glass types)

- BalcoNano® self-cleaning coating

Free instant quotes

www.balconette.co.uk



Colour options

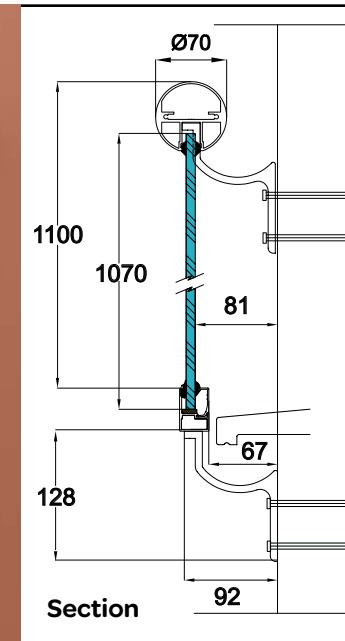
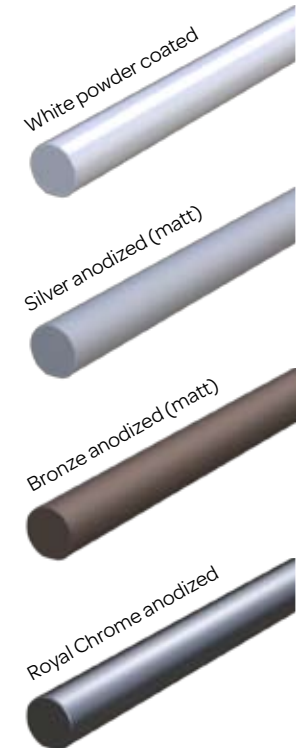

Technical details - Balcony 2 System (aerofoil handrail) Juliet



Standard sizes available	Glass options
1280mm handrail width	Standard models
1500mm handrail width	10mm clear toughened
1680mm handrail width	Custom models
1860mm handrail width	10mm clear toughened
2180mm handrail width	10mm green toughened
2450mm handrail width	10mm grey toughened
2840mm handrail width	10mm bronze toughened
	10mm blue toughened
	10mm satin (opaque) toughened
Custom sizes available	Optional extra (for all glass types)
Min 800mm handrail width	BalcoNano® self-cleaning coating
Max 4100mm handrail width	

Free instant quotes
www.balconette.co.uk



Colour options

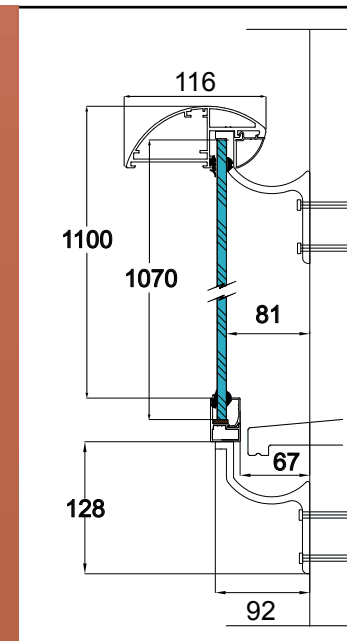
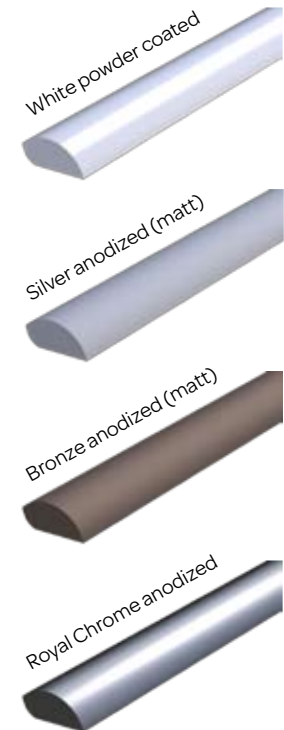

Technical details - Mirror Juliet Balcony System

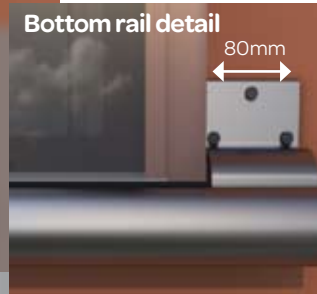
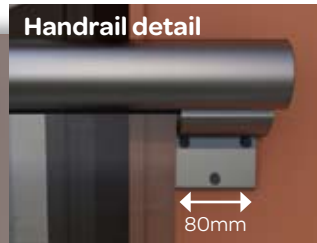

Standard sizes available	Glass options
1280mm handrail width	Standard models
1500mm handrail width	10mm clear toughened
1680mm handrail width	Custom models
1860mm handrail width	10mm clear toughened
2180mm handrail width	10mm green toughened
2450mm handrail width	10mm grey toughened
	10mm bronze toughened
	10mm blue toughened
	10mm satin (opaque) toughened
Custom sizes available	Optional extra (for all glass types)
Min 800mm handrail width	BalcoNano® self-cleaning coating
Max 2450mm handrail width	

Free instant quotes
www.balconette.co.uk



Colour options

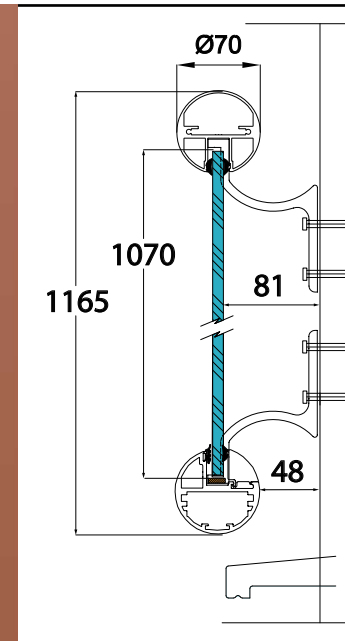
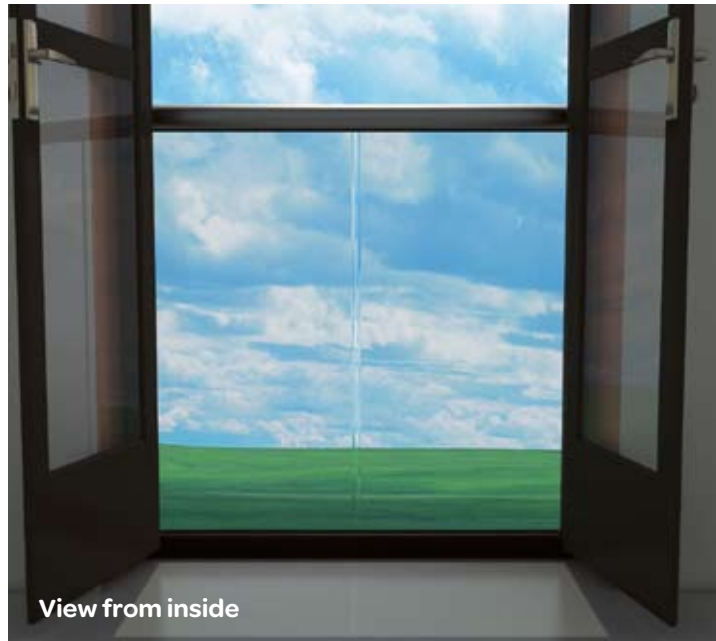

Technical details - Balcony 1 Balustrade System

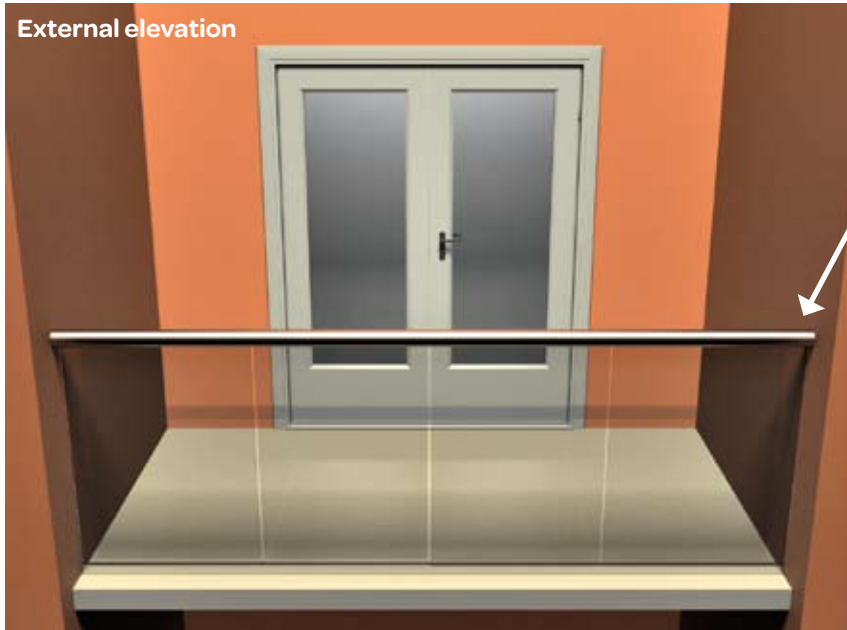

External elevation

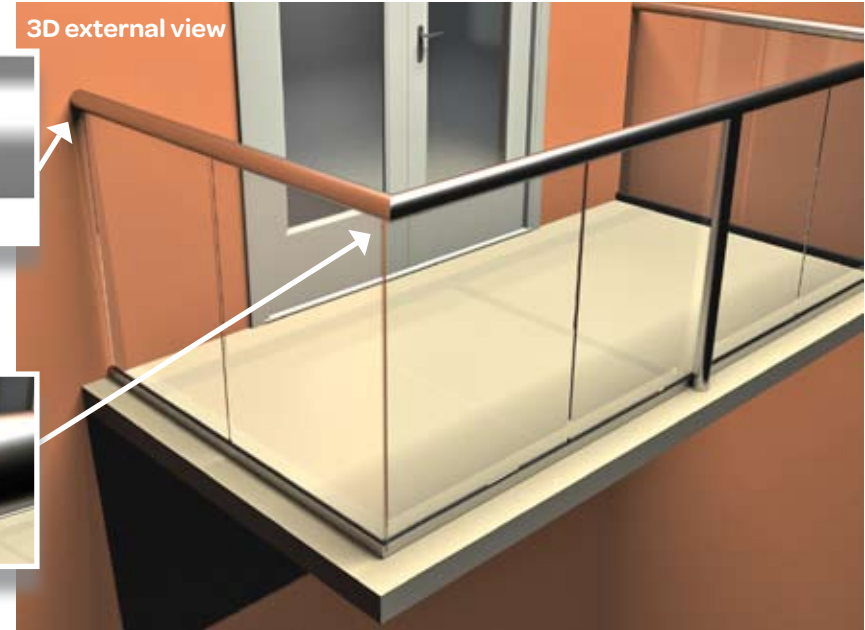

3D external view



Wall fixing detail



Corner detail

Section

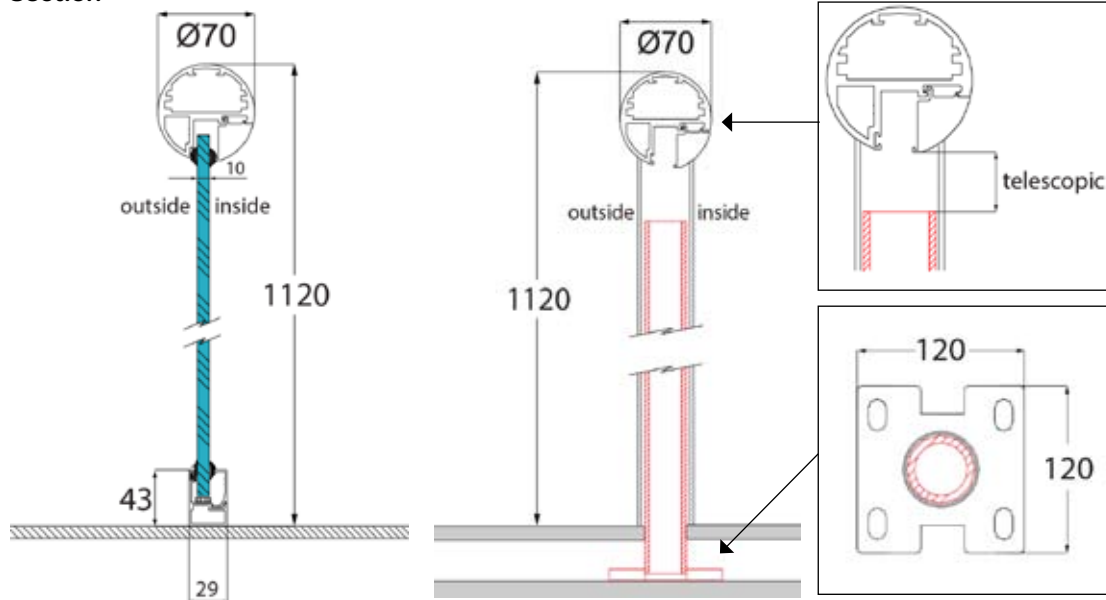

Parameters

Max structural length without posts 3300mm
Max post spacing 1900mm

Glass Options

- 10mm clear toughened
- 10mm green toughened
- 10mm grey toughened
- 10mm bronze toughened
- 10mm blue toughened
- 10mm satin (opaque) toughened

Optional Extras (for all glass types)

- BalcoNano© Self-cleaning coating
- Laminated glass options available

Colour options

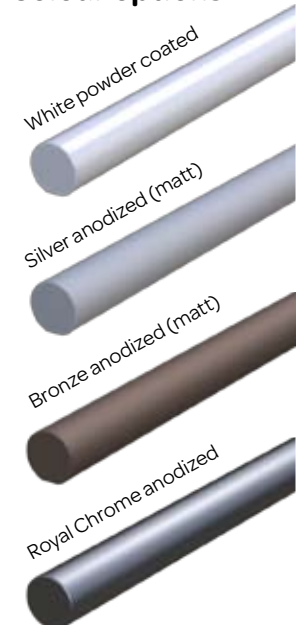

Free instant quotes

www.balconette.co.uk



Technical details - Balcony 2 Balustrade System



External elevation



Wall fixing detail

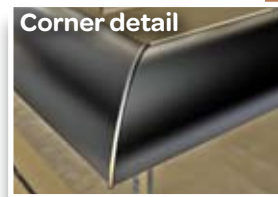

Corner detail



3D external view

Section

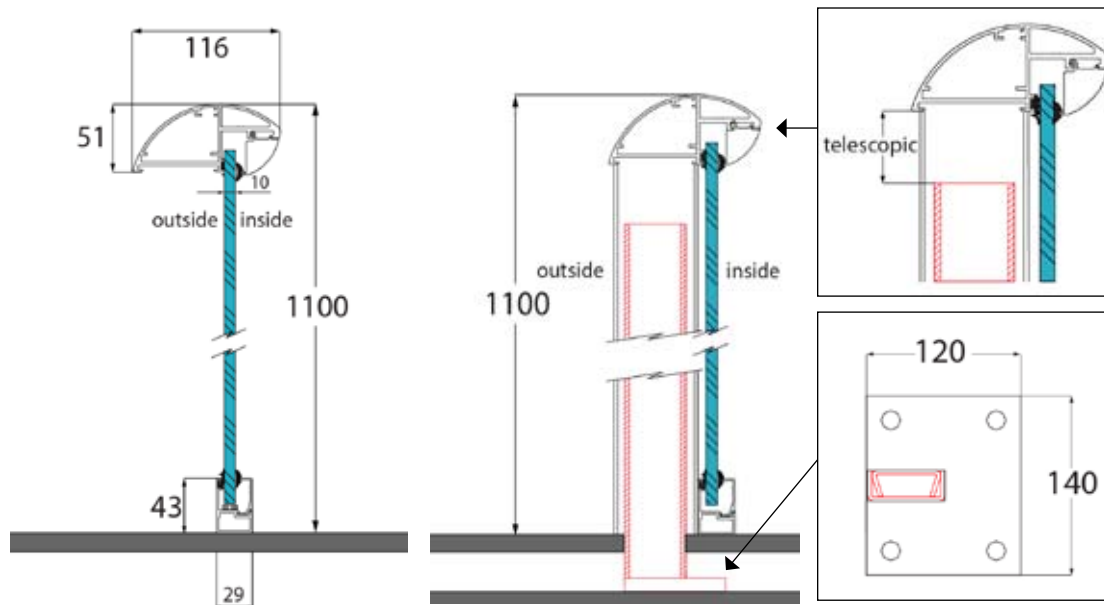

Parameters

Max structural length without posts 4000mm
Max post spacing 2100mm

Glass Options

- 10mm clear toughened
- 10mm green toughened
- 10mm grey toughened
- 10mm bronze toughened
- 10mm blue toughened
- 10mm satin (opaque) toughened

Optional Extras (for all glass types)

- BalcoNano® Self-cleaning coating
- Laminated glass options available

Colour options

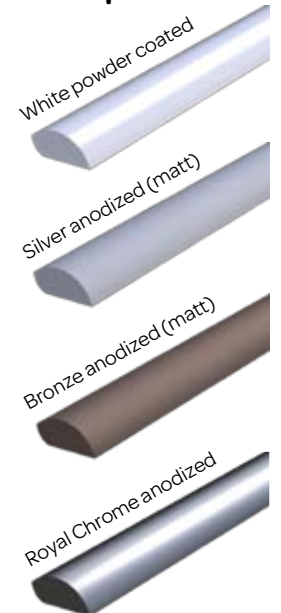

Free instant quotes

www.balconette.co.uk



Technical details - SG10 Semi Frameless System

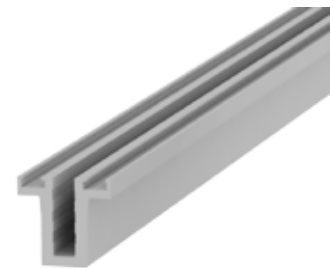
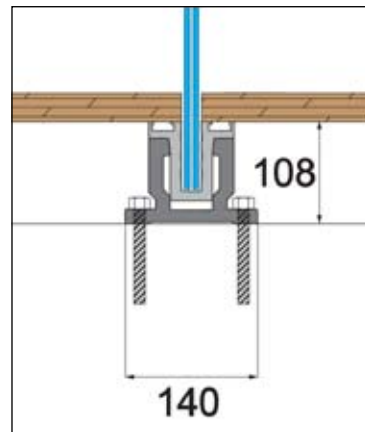
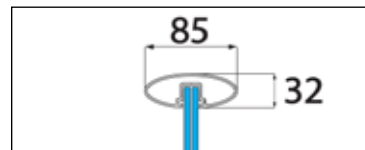
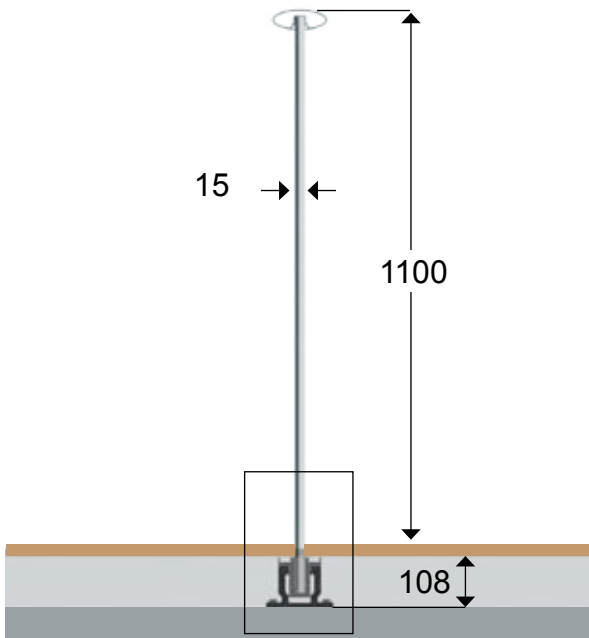
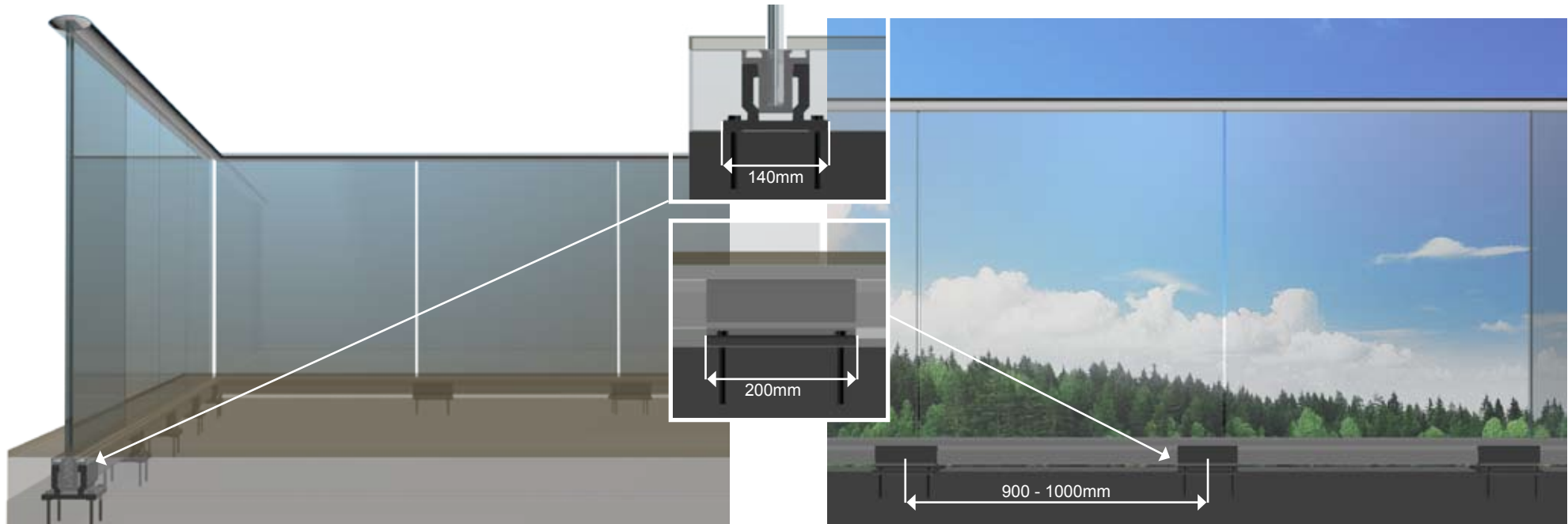

Continuous Glazing Channel



Base Fixing every 900 - 1000 mm

Parameters

Max structural length without posts: unlimited

Handrail colour options

Royal Chrome anodised

Glass options

15mm clear toughened

15mm satin (opaque) toughened

Optional extra

BalcoNano® Self-cleaning coating

Laminated glass options available

Free instant quotes

www.balconette.co.uk



Technical details - SG10 Fully Frameless System

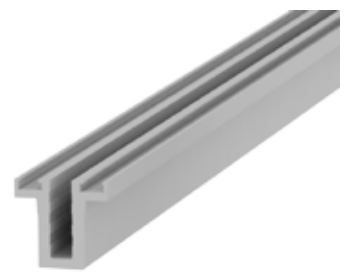
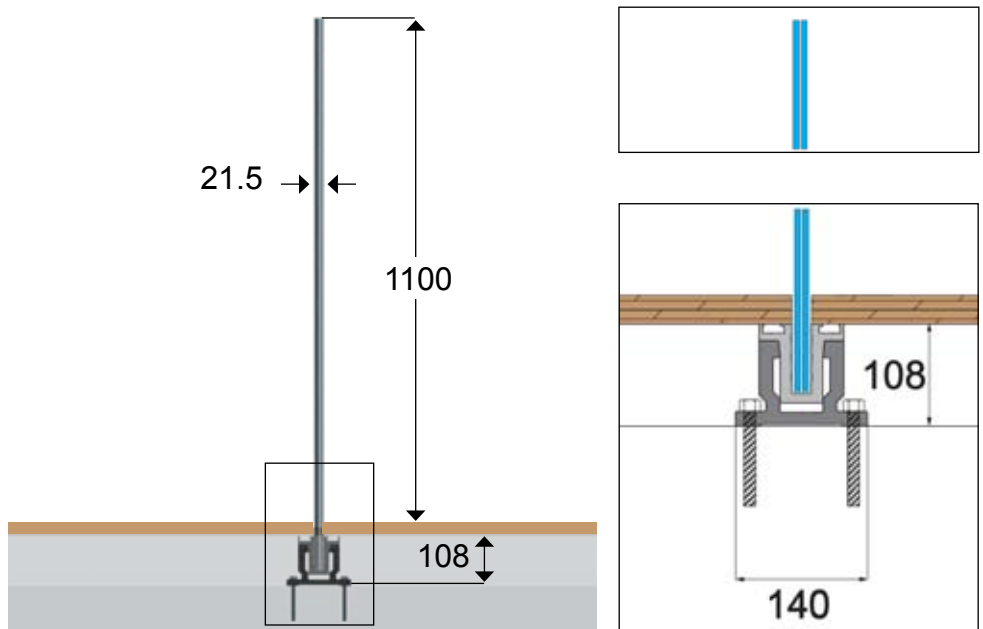
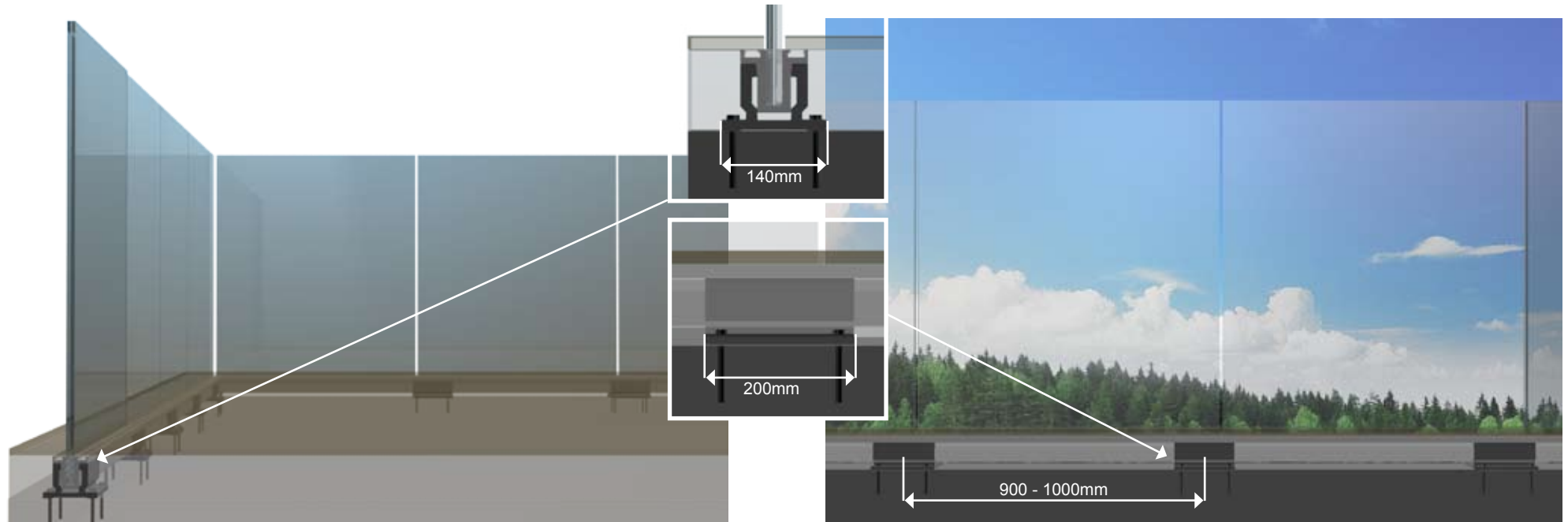

Continuous Glazing Channel



Base Fixing every 900 - 1000 mm

Parameters
Max structural length without posts: unlimited
Glass options
21.5mm clear toughened
21.5mm satin (opaque) toughened
Optional extra
BalcoNano® Self-cleaning coating

Free instant quotes
www.balconette.co.uk



Technical details - Curved Door Model W2F (2 doors - 1 sliding, 1 fixed)

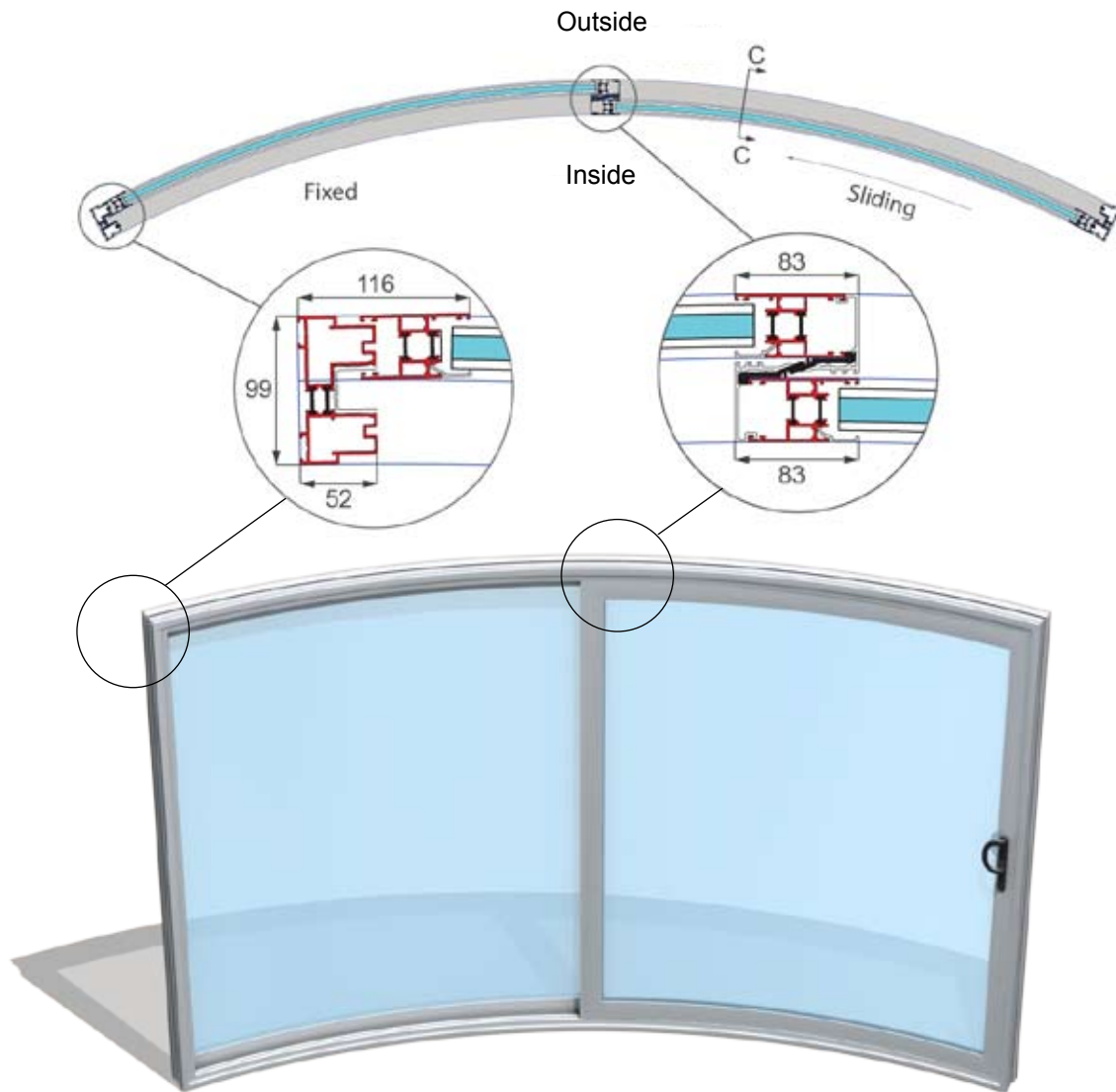

W2F Generic Section C-C

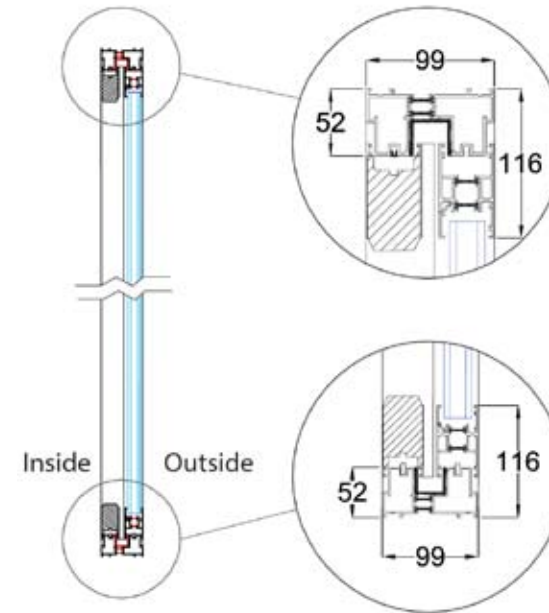

Section Profile Structure

Twin Polyamide Thermally Broken 6063 T5 extruded aluminium profiles, stainless steel wheel track

Paint/coating: 60-100 micron

Polyester powder coating in standard RAL colour, dual colour options available

Glazing

28 mm Toughened Low-E Double glazing in three options of centre pane U value; 1.7 W/m²K, 1.5 W/m²K or 1.0 W/m²K

Gaskets

EPDM(ethylene-propylene rubber) in black

Recommended Max Height

2600mm

Recommended Max length

3500mm (1750mm per sash)

Sliding Mechanism

Regular sliding, bottom rollers

Free instant quotes
www.balconette.co.uk



Technical details - Curved Door Model W3F (3 doors - 2 sliding, 1 fixed)

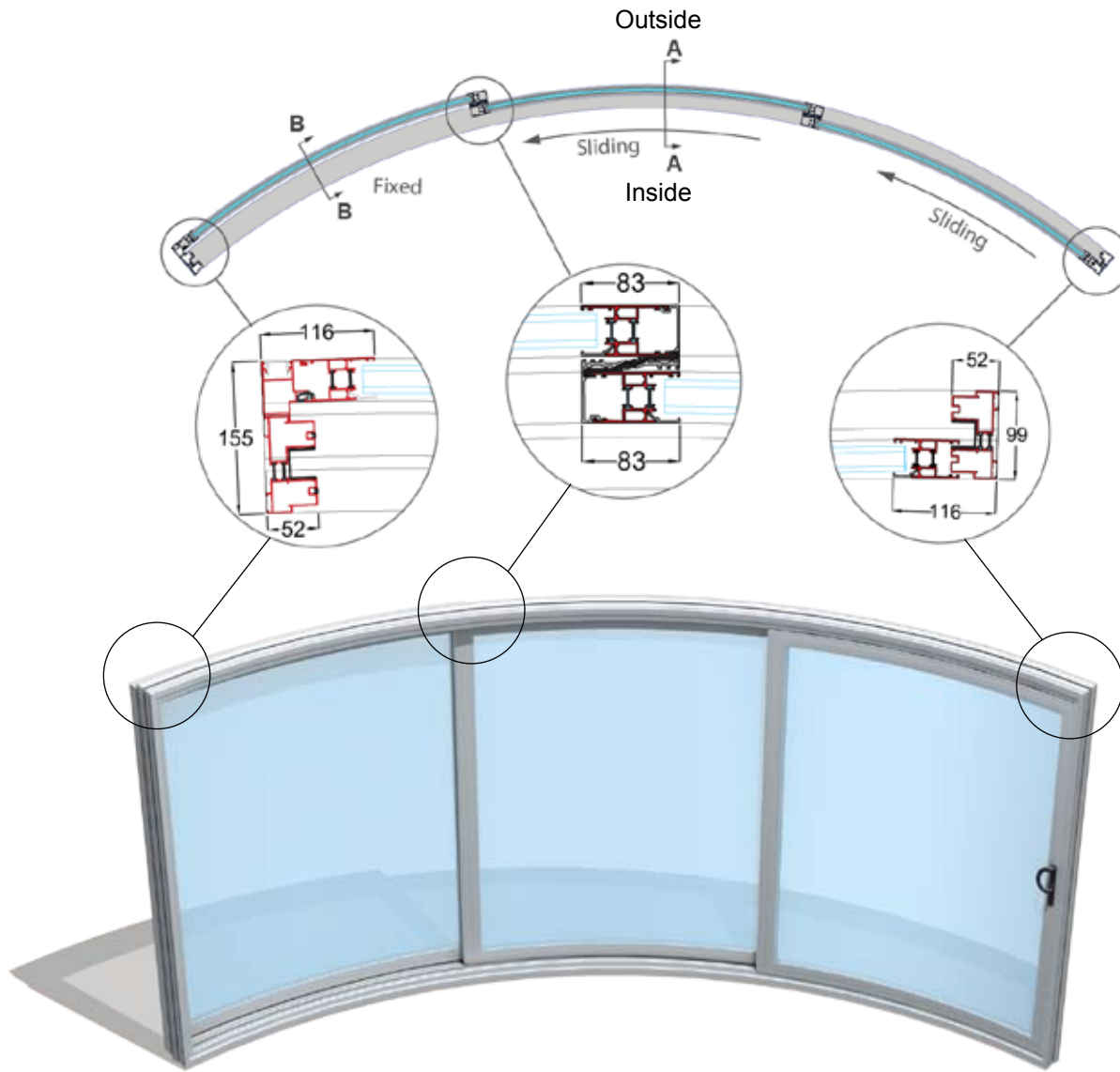

W3F Generic Section B-B

W3F Generic Section A-A

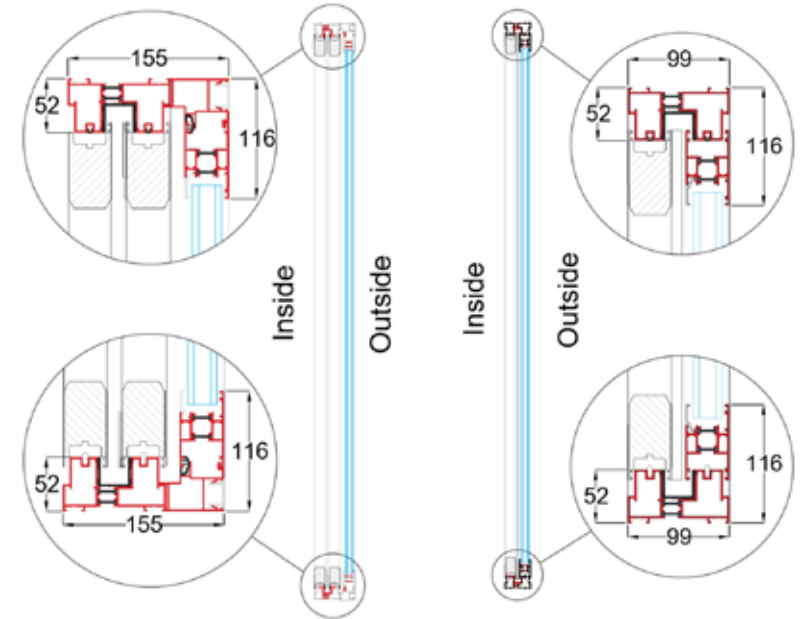

Section Profile Structure

Twin Polyamide Thermally Broken 6063 T5 extruded aluminium profiles, stainless steel wheel track

Paint/coating: 60-100 micron

Polyester powder coating in standard RAL colour, dual colour options available

Glazing

28 mm Toughened Low-E Double glazing in three options of centre pane U value; 1.7 W/m²K, 1.5 W/m²K or 1.0 W/m²K

Gaskets

EPDM (ethylene-propylene rubber) in black

Recommended Max Height 2600mm

Recommended Max length 5250mm (1750mm per sash)

Sliding Mechanism Regular sliding, bottom rollers

Free instant quotes
www.balconette.co.uk



Technical details - Curved Door Model W4F (4 doors - 2 sliding, 2 fixed)

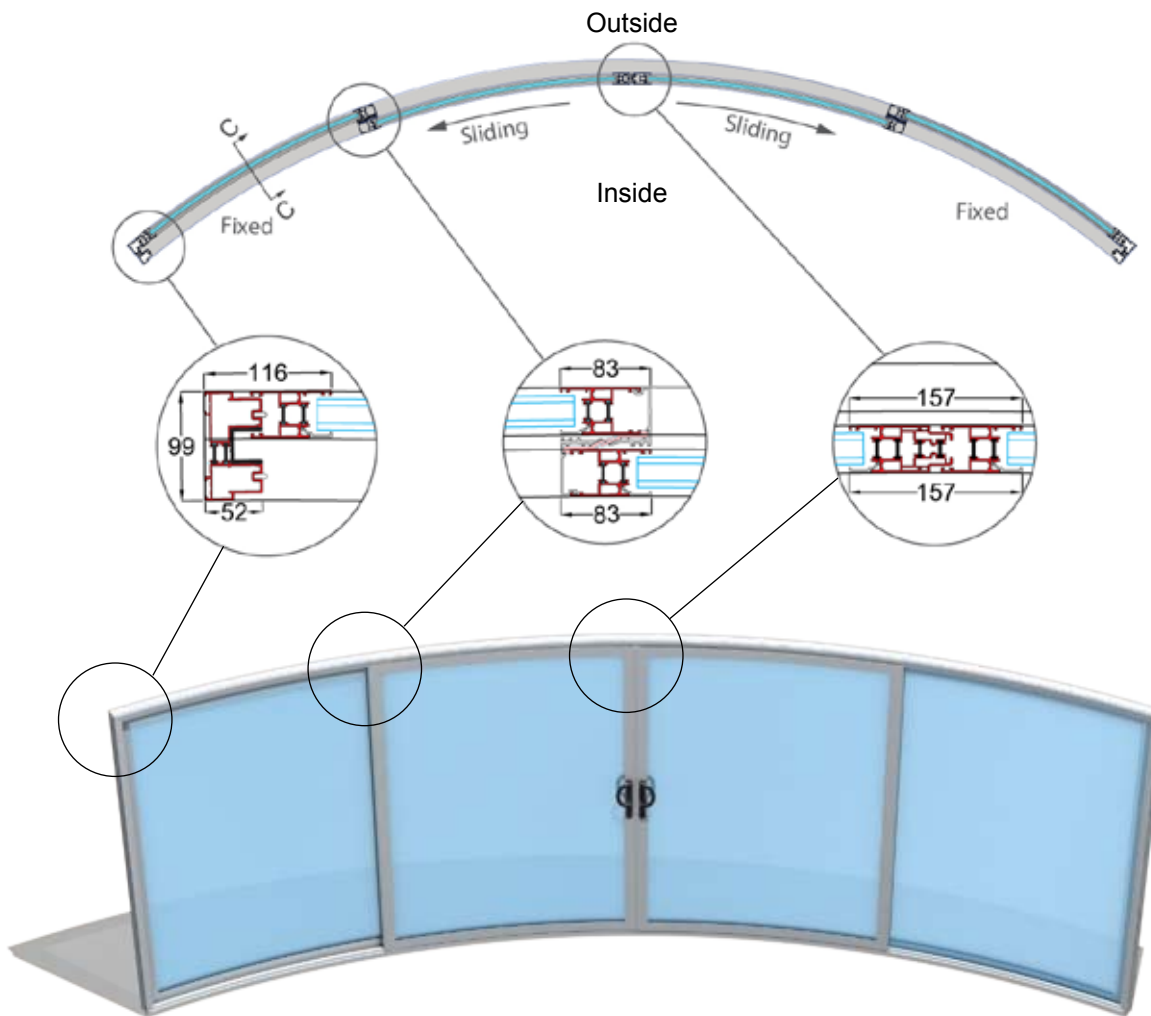

W4F Generic Section C-C

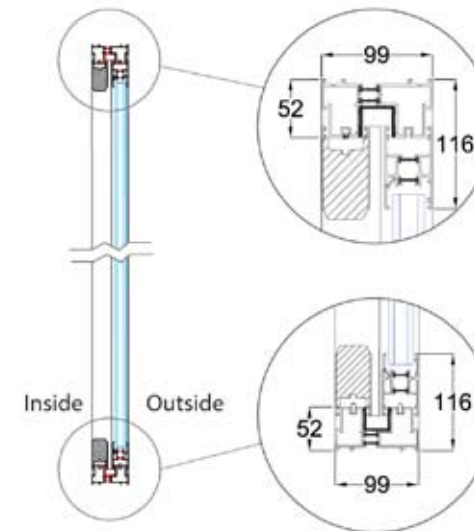

Section Profile Structure

Twin Polyamide Thermally Broken 6063 T5 extruded aluminium profiles, stainless steel wheel track

Paint/coating: 60-100 micron

Polyester powder coating in standard RAL colour, dual colour options available

Glazing

28 mm Toughened Low-E Double glazing in three options of centre pane U value; 1.7 W/m²K, 1.5 W/m²K or 1.0 W/m²K

Gaskets

EPDM (ethylene-propylene rubber) in black

Recommended Max Height

2600mm

Recommended Max length

7000mm (1750mm per sash)

Sliding Mechanism

Regular sliding, bottom rollers

Free instant quotes
www.balconette.co.uk



Technical details - Curved Door Model W6F (6 doors - 4 sliding, 2 fixed)

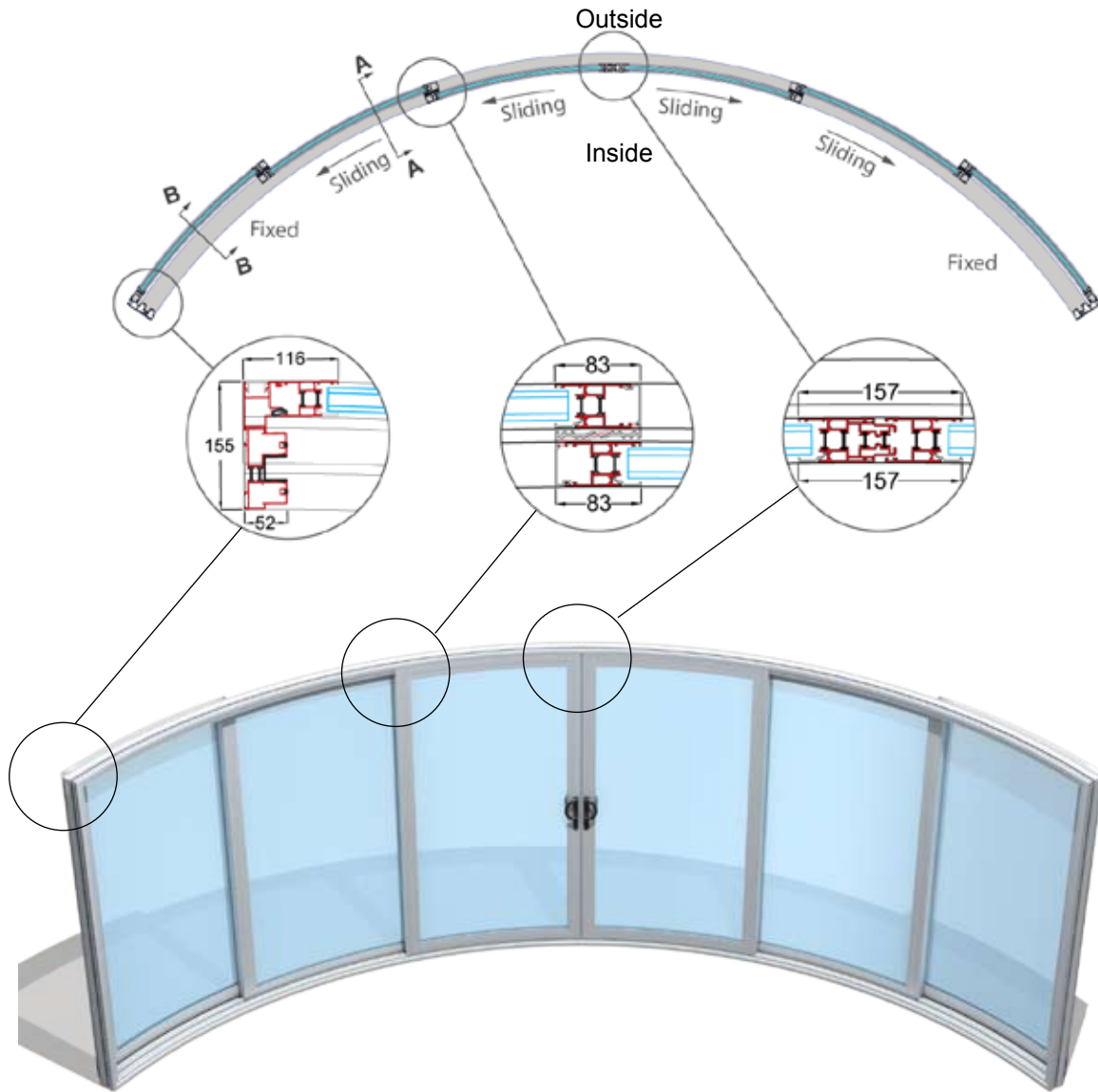

W6F Generic Section B-B

W6F Generic Section A-A

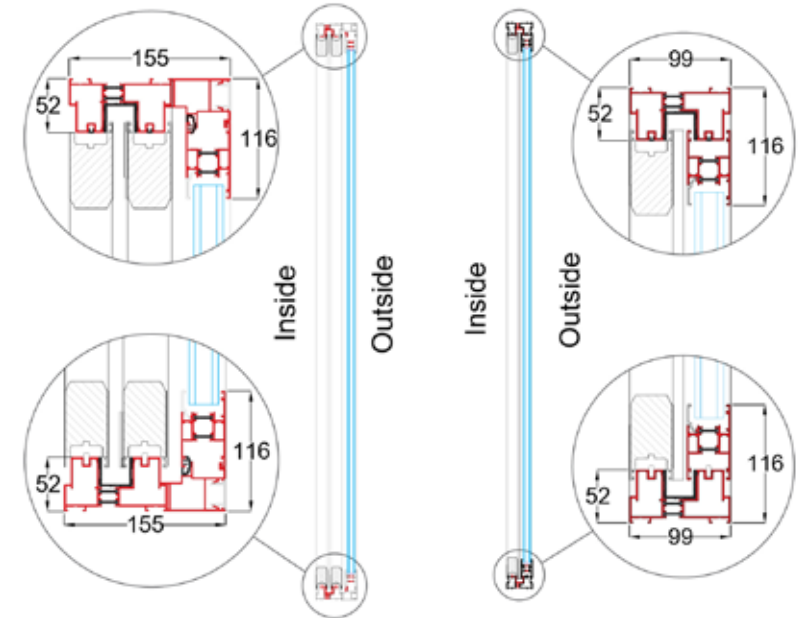

Section Profile Structure

Twin Polyamide Thermally Broken 6063 T5 extruded aluminium profiles, stainless steel wheel track

Paint/coating: 60-100 micron

Polyester powder coating in standard RAL colour, dual colour options available

Glazing

28 mm Toughened Low-E Double glazing in three options of centre pane U value; 1.7 W/m²K, 1.5 W/m²K or 1.0 W/m²K

Gaskets

EPDM (ethylene-propylene rubber) in black

Recommended Max Height 2600mm

Recommended Max length 10500mm (1750mm per sash)

Sliding Mechanism

Regular sliding, bottom rollers

Free instant quotes
www.balconette.co.uk



BalcoNano® Advanced Glass Coating

DIY Self-Cleaning Glass Sachets

An easy-to-use self-cleaning glass coating application

This unique coating has only been available in a factory applied version until now.

You can now apply the BalcoNano® coating yourself in an easy to use sachet application.

The double sachet contains a ready to use "wet wipe" towelette that is pre-soaked with the BalcoNano® coating and the BalcoNano® cleaner ready to use directly to the surface you wish to coat.

Balcony Systems have launched a revolutionary packaging that enables an easy DIY application.

No need for any prior experience of using the product, you can turn your existing ordinary glass into "self-cleaning" glass.



The sachet pack comes as a two part set, one sachet with the BalcoNano® glass cleaner and the second sachet containing the BalcoNano® coating.

Each sachet pack is suitable for coating approximately one square meter, or eleven square feet.

The long term cost savings from applying the coating are tremendous. Coated glass will require 50%-90% less cleaning.

BalcoNano® Shower Renovation Kit

Tired of irremovable streaks and marks on your shower glass?

The shower renovation kit includes all that you need to restore your shower glass to as new and protect it so it remains this way.

Shower glass is particularly prone to build up of scum, soap, calcium and other grime. A glass screen on a shower will get severely contaminated and dirty within only a few months of use.

The kit includes a 500ml bottle of the BalcoNano® heavy duty cleaner to be used in the first stage. This will remove the deep lodged dirt and particles.

After cleaning use the 10 double sachets of the BalcoNano® coating to protect the glass surface from future contamination.

The kit also includes a premium microfiber glass cloth which is perfect for removing heavier soilings from all hard surfaces. The micro fibres work through capillary action, drawing dirt into the cloth.

Also included is a pair of powder free blue nitrile gloves – the gloves provide superior resistance to chemicals,

Heavy Duty Glass Cleaner

A strong glass cleaner for lodged dirt, grime and other deposits that cannot be cleaned with regular cleaners

A strong glass cleaner for lodged dirt, grime and other deposits that cannot be cleaned with regular cleaners.

Why is it that some glasses will just not clean no matter how much you scrub?

Our unique formula for heavy duty glass cleaning will release some of the really deeply lodged deposits that have accumulated over time.

Some glasses that have severe surface deterioration and corrosion can sometimes be restored using this very strong glass cleaner that will release lodged dirt, grime and other deposits that cannot be cleaned with regular products.



The BalcoNano® heavy duty cleaner is only the first step in restoring the glass. Once the glass surface is clean from the imbedded contaminants, the BalcoNano® coating must be applied to protect the surface from future contamination.

The BalcoNano® heavy duty glass cleaner can also be used to remove the coating when needed so is not intended for use after coating the glasses.

cuts, tears and abrasions with a soft, conforming design whilst offering great levels of dexterity and sensitivity.

The kit contains:

- 1 x 500ml bottle BalcoNano® heavy duty cleaner
- 10 x BalcoNano® double sachet packs
- 1 x premium microfiber glass cloth
- 1 x pair of powder free blue nitrile gloves



www.balconano.com



Glass corrosion – can anything be done?

Glass quietly gets on with doing a fantastic job in our lives. It secures and lets light into our buildings, while also protecting us from the elements. Yet while every other component of a building, such as steel, aluminium, timber and concrete, has surface protection, glass is simply left bare and vulnerable to corrosion, contamination and degradation over time.

Build-up of grime and salt deposits, if not removed, can attack the transparent surface of glass turning it opaque. So why don't we do more to look after this often-neglected material which is essential for our well-being, when protective solutions are readily available?

“Build-up of grime and salt deposits, if not removed, can attack the transparent surface of glass turning it opaque.”

Have you ever experienced glass stains or streaks on glass that, no matter how hard you try to clean them, just will not budge? Why do shower enclosures get dirtier and more opaque over time?

Why does it seem impossible to remove finger prints from sandblasted glass?

Although glass may seem to have a smooth surface, the microscopic surface topography of glass is actually

uneven and pitted with peaks and valleys. This surface architecture is the hidden reason behind many glass-related problems.

To understand this problem we need to zoom into the surface of glass.

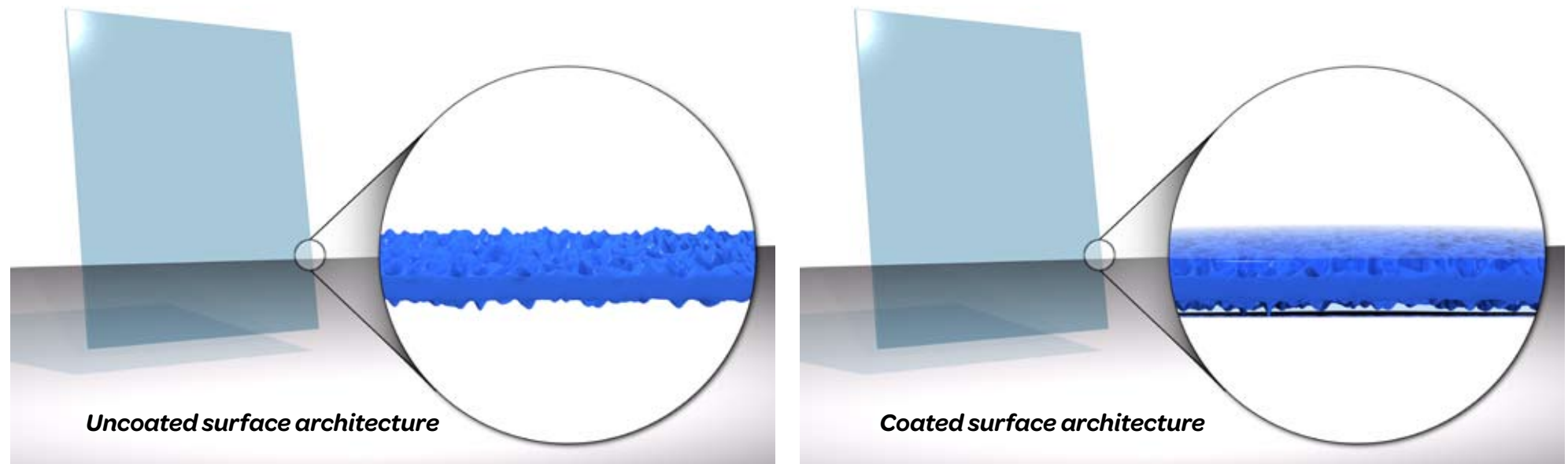

Glass surface naturally attracts water (hydrophilic), meaning that when water makes contact with the surface of glass the water will tend to spread out and form a thin sheet on the surface. When the water evaporates, all the mineral deposits it contained are left on the surface of the glass. These deposits, which include calcium, salt, heavy metals and a wide range of minerals, together with dust, grime, bacteria, soap scum and a long list of contaminants, embed themselves into the pits and valleys inside the surface of the glass.

These elements get lodged, building up over time, slowly making the glass surface more and more opaque, dirtier and harder to clean.

This phenomenon is amplified on glasses such as etched or sandblasted. This is because etching or sandblasting will make the surface even coarser, rougher and more prone to this problem than regular glass.

Anyone who has handled sandblasted glass will tell you that removing finger prints or dirt from this type of glass is a real nightmare.

Nature – showing us the way

It is curious how we find in nature some of the most advanced technologies that only in the last few years we, mankind, have been able to partially copy or imitate.

Some plants and creatures have created a brilliant way of staying clean. For example, we have the lotus leaf that possesses a very unique surface architecture; this architecture makes the surface of the leaf super-hydrophobic, which means super-water-repellent. Water that comes into contact with the leaf, curls up almost into a ball, leaving an absolute minimum amount of contact with the leaf's surface. Not being able to cling to the surface of the leaf, the water droplets will cling onto anything else on the surface, namely any dirt or dust. This dirt and dust on the leaf's surface gets washed off by these droplets leaving the leaf clean.

The lotus effect

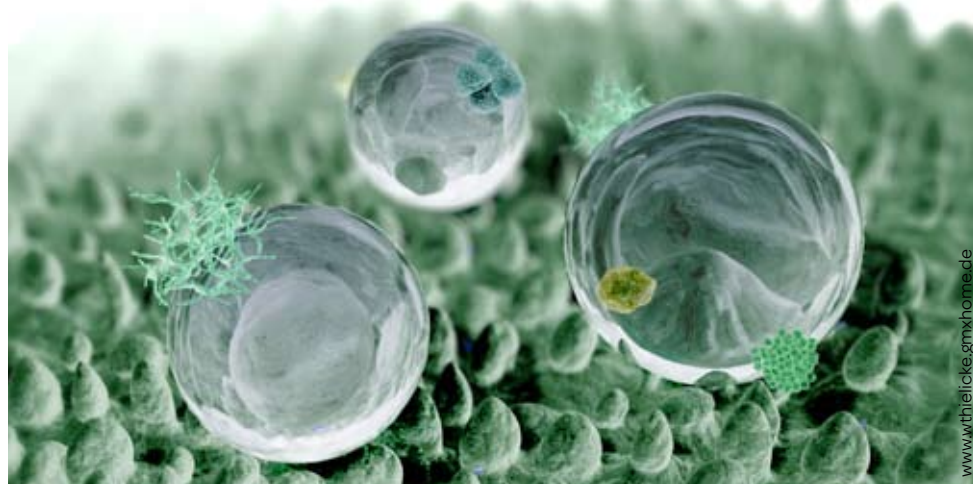

The solution – BalcoNano® advanced glass protection

Inspired by the lotus leaf's self-cleaning technology, we have created a unique and very durable coating for glass that actually transforms the surface architecture of glass, turning it from a hydrophilic (water-attracting) into a hydrophobic (water-repelling) surface.

How BalcoNano® advanced glass protection works

At only 20 nm (nanometre) thick, BalcoNano® works at the nano-scale level – a nanometre is one billionth of a metre or one millionth of a millimetre (1 millimetre = 1,000,000 nanometres).

The BalcoNano® coating forms a hard, clear and super-smooth surface on the glass, covering entirely these problematic pits, peaks and valleys of the underlying glass surface. It transforms the surface into one that is charged and water-repellent. Water that now comes into contact with the coated glass will not have access to the pits and valleys; water will sit high on the surface and the droplets will tend to curl up and quickly roll away.

Dirt, grime, calcium and other deposits will not be able to embed themselves into the surface and will wash away easily. Teflon is a good comparison. Just as Teflon protects the underlying metal on a frying pan, so BalcoNano® protects the underlying glass surface.

**“Costing only
£20 per square
metre for coating
to both sides
of the glass,
can you really
afford not to
add this?”**

*“Completely transparent
ensuring your enjoyment of the
glass is not limited in any way.”*



BalcoNano® is factory-applied shortly after the glass processing is complete. The glasses are deep-cleaned and then put into an enclosed chamber where they are exposed for a few hours to a series of vapours that form the unique BalcoNano® surface.

The chamber application has an added benefit in that the BalcoNano® surface coating is created simultaneously on both faces of the glass, protecting the glass on the inside and outside at the same time.

Completely different to any manual application, the chamber system is an ultra-efficient method that allows us to process large amounts of glass in every chamber cycle. The process is closely monitored by a computer that constantly

checks temperature, humidity and air flow so the resulting coating can be replicated exactly every time.

Using this method we can apply the BalcoNano® coating to the glass on our balustrades, glass Juliet balconies and curved glass double glazed units.

Benefits of the BalcoNano® coating:

What are the benefits of the BalcoNano® coating? And is it worth the extra cost?

Here are some of the benefits:

- Protects the glass from lodging of dirt, grime and other contaminants
- Forms a hard water-repellent surface on the glass

- Reduces required frequency of cleaning between 50% and 90%
- Eco-friendly & pocket-friendly - eliminates the need for harsh chemical cleaners
- Increases impact & scratch-resistance
- Makes the glass surface graffiti-proof
- Keeps glass looking NEW for longer
- Completely transparent ensuring your enjoyment of the glass is not limited in any way
- Costing only £20 per square metre for coating to both sides of the glass, can you really afford not to add this?

Can the BalcoNano® coating be applied to existing glasses?

As customers began to recognise the immense benefits of the BalcoNano® self-cleaning glass coating, demand quickly followed for an on-site application for other glass products and elements so these too can enjoy

the protective assets of the coating.

Balcony Systems rose to the challenge and created a “DIY self-application” pack for on-site application of the BalcoNano® coating.

BalcoNano® can now be applied to glass that is already installed using the sachets system. Each sachet pack contains the required two-part system, a special glass cleaner and the BalcoNano® coating. Each sachet contains a pre-soaked towelette ready for immediate use.

The sachets are designed to be used by the homeowner or professionals alike, enabling the unique coating to be applied to existing glass in doors and windows, conservatories, shower enclosures and much more.

The coating chemistry works just as well on other silica-based products such as ceramics, porcelain, marble and stone. This means the sachets can be used to apply the coating to kitchen tops, sinks, ceramic tiles and many other areas.





BalcoNano[®] brings the beauty back to glass balconies

If your glass balcony has lost its sparkle, then Sue O'Sullivan's uplifting story should inspire you to try BalcoNano's BalcoNano[®] self-cleaning glass coating that converts ordinary glass into self-cleaning glass.

A single application of BalcoNano's product has transformed the glass balcony on an extension to her holiday home in Dundererry, Cornwall by preventing build-up of salt deposits and keeping the balustrade much clearer and cleaner.

Sue explained: "Having 'normal' glass in a coastal location was not a good idea as the balustrade was completely opaque with sea

salt within a week of being installed. After first applying the BalcoNano[®] product, my balcony didn't require cleaning for more than two years!

"Admittedly, it did need cleaning after then, but still looks amazing considering that," she added. "It's had a tremendous effect and looks so much better. The property is right next to the sea, it can't be any closer, which only goes to show how effective the product is!"

"After first applying the BalcoNano[®] product, my balcony didn't require cleaning for more than two years!"



Customer feedback on the BalcoNano® coating

Here are some testimonials from more customers who have ordered the BalcoNano® coating for their balustrades, Juliet balconies and other glass products.

Graham Spencer of London, said:

"Having used the coating on a shower cubicle, I can say it helps to keep the glass cleaner. Overall, I would say it's better to have it on than not."

Anne Edwards of Devon, said:

"I have noticed a difference on a couple of hard-to-reach Velux windows. They do stay cleaner and I am pleased with the product. I will be using it on more windows other than the Velux ones."

Rachel Brickley of Battersea, London, said: *"The coating has worked really well on the full-length mirrors in my shower. I've definitely noticed a difference and it has reduced the cleaning a lot. Definitely recommended!"*

Craig Williams, Managing Director, Blind and Track Service Ltd, Salisbury, said:

"I have used the BalcoNano coating on two glass conservatory roofs and the feedback from the clients has been very good. It is working really well for them and they say the roof stays cleaner than it did before."

William Davies of Milton Keynes said:

"We purchased the coating for high-access Velux windows in one of our rental properties to reduce maintenance. As the windows are difficult to access and clean, we think it's a good idea to use a product that will keep the glass cleaner for longer."

Mildred Hindle of Preston said: *"I applied it to my shower screen and it's very good. I'm very impressed with it. It's an excellent product. In fact I've recommended it to several people. The coating makes everything easier to clean without a shadow of a doubt. You can see it working and it's so simple to just rinse the glass with the handheld shower afterwards."*

Summary

As architects, developers, homeowners and self-builders become more knowledgeable and understand the reasons behind glass dirt retention the need becomes apparent for a cost-effective and durable solution.

The BalcoNano® glass coating presents an eco-friendly and durable solution that literally pays for itself, both in saved cleaning frequency & time, plus in eliminating the need for use of expensive chemical cleaners.



"The BalcoNano® glass coating presents an eco-friendly and durable solution that literally pays for itself."

Sub contents

- Board colours, finishes and options
- Finishing touches
- Installation options and features
- Advantages and specifications
- Case study: balustrade and decking - perfect partners

Balcony Systems' Composite Decking

Why is this different and better?

The durable top layer is anti-abrasive, anti-slip, UV stable, resilient.

Highly resistant to scratches and stains.

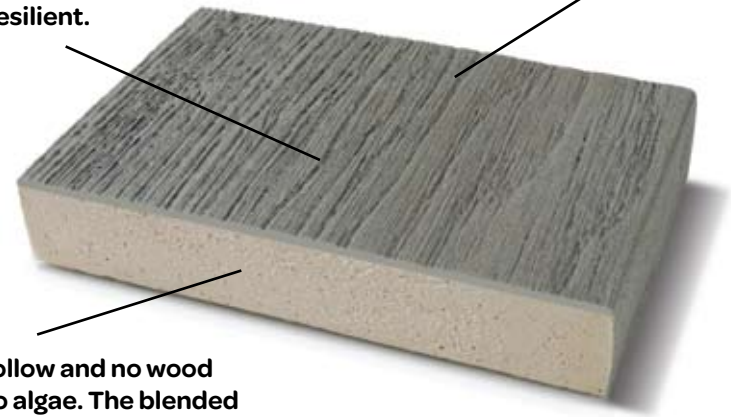

Solid, not hollow and no wood content = no algae. The blended polymer resin does not rot, warp or crack.

Balcony Systems' Composite Decking is a new generation of external flooring that perfectly complements Balcony Systems' existing product portfolio.

This innovative decking solution is made from a unique polyurethane and mineral blend providing long-lasting durability with minimal maintenance.

The composite decking is very low-maintenance as it does not absorb or give off moisture or swell and shrink like wood. It is also coated in a UV stable hard wearing polymer, which is a non-porous substance that resists the growth of algae as well as having self-cleaning qualities.

Balcony Systems offers a full decking range including finishes such as Enhanced Grain (Jarrah, Coppered Oak, Golden Oak, Smoked Oak, Limed Oak), Weathered (Driftwood and Vintage) and Carbonised (Charred and Emberred).

Our decking combats the common drawbacks of solid wood decking:

- **Does not rot**
- **No warping or cracking**
- **Slip-resistant surface**
- **Looks like real wood and retains the colour**

Driftwood

Board colours, finishes and options

With a range of different textures and colours to choose from, there's a decking product to suit your individual requirement - adding character and style to your balcony or outdoor space

Enhanced Grain (smooth, wood-grain finish)



Jarrah



Coppered Oak



Golden Oak



Smoked Oak



Limed Oak

Carbonised (burnt wood finish)



Charred



Emberred

Weathered (aged wood finish)



Driftwood



Vintage



Jarrah

Finishing touches

Decorative fascia boards and step edgings add those all-important finishing touches to your decking project.

Decorative Edging

Available in a Bullnosed or Ribbed design, this edging product is invaluable whenever there is a change of level to provide a seamless finish. Both edgings are available in rigid (standard) and flexible material and are available in the full range of colours.



Fascias

Decorative fascias are supplied rigid as standard but can also be requested in a flexible style to follow the shape of curved decking. They are also available in a variety of colours, perfectly matching the decking to give a neat and tidy finish to any installation.



“... available in a variety of colours, perfectly matching the decking to give a neat and tidy finish...”

Installation options and features

Fixings

Ghost Fixings – they are there but hardly visible

Installation is simple as Balcony Systems' stainless steel Ghost Fixings 'lost head' fixings just screw in. The screw is hidden

as the composite decking board 'self-heals' back over itself, leaving virtually no mark for a cleaner finish.

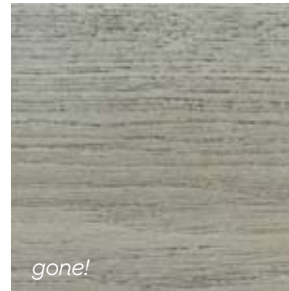

"The screw is hidden as the composite decking board 'self-heals' back over itself..."



Water Resistant Sub Frame

As the ideal partner to complement any of Balcony Systems' decking products, this sub frame solution enables us to offer complete non-rot external flooring systems for a variety of applications.

Made from 100% recycled plastic, it does not rot, split or crack and is suitable for damp/ wet areas including jetties, fishing platforms, boardwalks and roof terraces.

Water resistant subframe specifications

Type	Dimensions	Colour
Post	100 x 100 x 3000	Black
Joist/ Bearer	125 x 50 x 3000	Black
Joist*	50 x 50 x 2400	Black
Joist**	100 x 38 x 3400	Black

* Used for roof terraces or solid base only

** Residential applications

Made from 100% recycled plastic, it does not rot, split or crack...



Joist Shoes

Suitable for use with any of Balcony Systems' Decking products, joist shoes are ideal for use on hard surfaces. They are also widely used on roofs as they do not puncture the roof membrane; allow water to flow between joists and roof and create an air gap for 'breathability'. A further benefit of the joist shoes is that they reduce sound transfer.



Joist Spacing

For residential use, a joist spacing of 400mm is recommended and on heavy commercial, bridges, balconies, moorings, doorways and steps a 300mm joist spacing is recommended. (A minimum of 3 joists are required for any cut boards.)



Pedestals

Balcony Systems' adjustable roof pedestals are ideal for decking on balconies. Pipework can be laid underneath while allowing room for breathability and preventing rot in the joists. Adjustable pedestals are available up to 220mm high.



Ring supports

Ring supports are designed for low height areas creating airflow and protecting the roof membrane. Water can flow off easily, preventing pooling.



Advantages and specification of Balcony Systems' Composite Decking



The inspired decking solution

Unlike natural wood decking, Balcony Systems' Composite Decking is durable and long-lasting due to its polyurethane and mineral blend. It is also protected from UV rays. Natural timber is extremely porous and hosts algae growth, whereas composite decking is virtually maintenance-free, non-porous, does not host algae and has self-cleaning properties. Because there is no algae growth, this reduces the risks of accidents and slipping.

For areas where food and drink is served, Balcony Systems' decking is the ideal choice. Anything that is accidentally spilt can be easily wiped up leaving no stains or marks. Staining can be a problem with timber decking as stains are more difficult to remove from wood.

Advantages

- **Virtually maintenance-free**
- **25-year residential warranty**
- **Resistant to scratches and stains**
- **UV Stable**
- **Versatile**
- **Doesn't warp or expand like wood**
- **Durable and anti-abrasive**
- **Doesn't host algae growth**
- **Safer and cheaper alternative to wood**

	UV stable hard wearing polyurethane	146 x 2400 x 18	176 x 3600 x 32	200 x 3600 x 32	50 x 2400 x 33	Colour options					Fixing type	Coverage inc 4mm gap	
						Coppered Oak	Driftwood	Golden Oak	Limed Oak	Smoked Oak	Vintage	Ghost Fixings stainless steel trimhead	Boards per M ² Installed
enhanced grain	•		•			•		•	•	•		•	1.54
weathered	•			•			•				•	•	1.36
ribbed edging	•				•	•	•	•	•	•	•	•	n/a
bullnosed edging	•				•	•	•	•	•	•	•	•	n/a
fascia board	•	•				•	•	•	•	•	•	•	n/a

Balcony Systems' balustrade and decking are perfect partners

Glass balustrading and composite decking from Balcony Systems make perfect partners for gardens as demonstrated by this elegant example at Crowborough, near Tunbridge Wells, Kent.



Limed oak

Summers spent outside await a delighted Deborah and Nigel Gooch after giving their original 14-year-old paved patio a complete 'low-maintenance' make-over.

The new decking, in a pale Limed Oak finish, is made from a unique polyurethane and mineral blend providing long-lasting durability with a slip-resistant surface and minimal maintenance. It is complemented with the Balcony 1 balustrading system using Balcony's proprietary Royal Chrome anodised finish handrail.

The couple also specified Balcony's BalcoNano® self-cleaning glass coating on the curved and straight panels which noticeably reduces the need for cleaning. The protective coating creates a smooth, water-repellent surface so dirt and other deposits cannot cling and are easily washed off by rain or wiping with a wet cloth.

"The end result is absolutely stunning, to say it's a transformation is an understatement," enthuses Deborah. "It really has transformed the whole garden and it all looks so much better and brighter. The smoothness and uniform colour of the decking makes the area look bigger, although it is still the same size."

"We also replaced old wooden decking by the pond which was a no-go area in the winter because it was so slippery with mould. It was literally a 'death-trap' from October to March, but now we can use it safely all year-round."



Limed oak

When planning their patio renovation, Deborah and Nigel, who have a young granddaughter, considered rope or railings to provide a barrier to the four-foot drop below. "No one had fallen off in 14 years, but a two-year-old might. We struggled to find a suitable balustrade as we didn't want to block the view," continues Deborah.

A visit to a local garden with a 'fantastic glass balustrade' inspired them to contact Balcony Systems who put them in touch with Peter Leck and Simon Ritchie's Tunbridge Wells based installation company, one of Balcony's Approved Installers across the UK.

Deborah explains: "Until then, I didn't know about glass balustrading but realised that it was the solution we needed. Finding the glass was a real revelation, matching our requirement to keep the garden views. Then Simon's suggestion to also install Balcony Systems composite decking was

brilliant. The two products go together beautifully and have given us a lovely new outdoor space to enjoy.

"We also replaced old wooden decking by the pond which was a no-go area in the winter because it was so slippery with mould. It was literally a 'death-trap' from October to March but now we can use it safely all year-round."

Being able to offer both balustrading and decking has expanded the options for Balcony Approved Installers like Peter and Simon. "Customers appreciate the convenience of being able to have the complete design-to-installation package from one company which also gives them peace of mind throughout the entire process," says Peter.

He adds: "Both products offer great versatility and work together so well to create a fabulous-looking solution like this one!"



"The end result is absolutely stunning; to say it's a transformation is an understatement," enthuses Deborah.

"It really has transformed the whole garden and it all looks so much better and brighter. The smoothness and uniform colour of the decking makes the area look bigger, although it is still the same size."

Limed oak

Join Balcony Systems' National Network of Professional Installers

Balcony Systems operates a growing Registered Installer programme throughout the UK, stretching from Cornwall to the Isles of Scotland.

Balcony's approach is to develop long-term partnerships with trade customers who sign up to its national network of independent professional installers. The comprehensive support package includes training, product discounts, referral of enquiries and dedicated literature to help close sales, as well as installation advice.

Advanced partners can also have access to Balcony Systems proprietary pricing and technical drawing software,

"We are always looking for professionals who we can collaborate with and recommend as potential local installers of our products to clients in their area," says Effi Wolff, Balcony Systems Managing Director.

"Our expanding network has helped to open up new sales opportunities for window, door and home improvement companies as well as installers and builders involved in all types of fenestration, refurbishment and improvement projects."

Balcony Registered Installers can offer clients a full service, from initial site surveys, design and drawings through to final installation, ensuring complete customer satisfaction from start to finish.

Impressed after seeing the quality and aesthetics of Balcony's products at Grand

Designs Live, **David Bromley** became a Registered Installer and offers a full installation service in the North West.

"When we saw the stand, my thought was 'Wow!' and my operations director Robert Allen was blown away. We were gobsmacked by the amazing product range and decided we wanted to do this," says David.

"Balcony's support has been great. We've developed a close working partnership and with access to their sales quotation and technical drawings software, we feel like an extension of their business. Balcony helped us with creating our new website and enquiries are coming in providing new opportunities for us in the private residential sector," he continues.

"Balcony's products offer a wonderful combination of affordability and fantastic looking products to the homeowner. We are thrilled to be part of the Registered Installer network and are very hopeful and confident that great things will come from it," adds David.

For Aberdeenshire-based joiner **Simon Elms**, becoming a Balcony Systems' Registered Installer has added sales and given his business a new dimension with



"Our expanding network has helped to open up new sales opportunities for window, door and home improvement companies."

mutual benefits. He signed up having been impressed with Balcony's glass and aluminium balustrading system he installed for a client.

"I've used a number of balustrading systems and the Balcony Systems' one is certainly a good quality product that sells - and at a very competitive price. Decking systems frequently need a secure barrier and working with Balcony Systems has given me another 'string to my bow'," says Simon.

"It has opened up opportunities for more work; for example, architects are asking me to quote for installation projects having been referred to me through Balcony Systems. In turn, I'm introducing more people to them so there are definitely reciprocal benefits," he adds.

For Kent based **Peter Nelmes**, who has been working with Balcony since 2005, being part of the network has improved his business 100%. He says: "Balcony refers leads to me and they're keeping me very busy. Having worked with balustrades and railings most of my life, I can say for a fact that the Balcony Systems' glass balustrade

is very well designed and you can tell that it has come from people who have worked on site and it goes together a treat."

Welding and fabrication business owner **Alan Snowden**, who joined the network in 2012 as a Registered Installer for the South West, is convinced of the benefits. He says: "I get quite a few leads from Balcony; they're a great team with really good products that look sleek and are easy to install."

He adds: "The anodised aluminium handrail does not rust so it's perfectly suited to the coastal climate here. Clients also like the post-less system that keeps clear views. They all choose the self-cleaning glass coating too as it enhances the products' low-maintenance." Joining the network in 2011 has helped to grow **Peter Leck** and **Simon Ritchie's** Tunbridge Wells-based installation company. They comment: "It's definitely added an extra element to our business and the products are easy to install. It's the best balustrading system available, in my opinion, which is why we find it easy to sell to our customers."

Balcony Systems continues to expand



“The general economic upturn and greater activity in the construction sector is having a positive impact on our business which continues to grow year-on-year.”

Balcony Systems continues to go from strength-to-strength since moving to its UK headquarters at Blindley Heath in Lingfield on the Sussex and Surrey border in 2010. Since then, sustained investment in people, premises and products has continued to drive the company forward.

Located in a prominent position on the main A22 Eastbourne Road only a few miles from the M25 and M23, the site is easily accessible for visitors from across the UK and beyond. The premises comprise of warehousing and manufacturing areas together with a showroom and spacious offices for the technical, sales and administration functions.

In recent months, manufacturing output has risen by 50% and staffing

levels increased by 20% in response to demand across Balcony’s product portfolio from all market sectors. Growth has also been boosted with new products including an expanded Juliet balcony range and wood-free external decking.

“The general economic upturn and greater activity in the construction sector is having a positive impact on our business which continues to grow year-on-year,” comments Effi Wolff,

Balcony Systems Managing Director.

“As a result, we are continuing to invest in our premises, personnel and machinery to maintain our position as one of the UK’s leading suppliers of glass balustrading and curved sliding patio doors,” he continues.

Effi states that their decision to move into larger premises during uncertain times ‘proved correct by giving us the necessary space for expansion, both now and for

the future, enabling us to maintain investment to keep ahead of the game and remain an influential player in the field.’

He adds: “With our investment plans in place, we are looking to the future with confidence servicing the market both locally and abroad.”

Balcony Systems ... passion for excellence

Balcony Systems is one of the UK's leading specialist solution providers of innovative and aesthetically-stunning glass balustrades, Juliet balconies, decking and sliding curved patio doors.

Balcony's technically-advanced and unique proprietary systems have been developed from many years of passion and experience to give spectacular, design-led results.

Curved and bespoke shapes can be accommodated through their extensive manufacturing expertise, which includes their own aluminium and glass bending capability.

Balcony is specified by architects, contractors, developers, home improvers and self-builders alike.

Balcony's unique products allow the creation of exciting unusual designs and shapes for all types of new build, refurbishment and renovation projects.



All Balcony Systems' products are designed with low-maintenance in mind and they are the first to offer a unique self-cleaning glass coating across their entire range. Glass can be specified with their proprietary and double-sided BalcoNano® self-cleaning glass coating that reduces cleaning cycles.

From individual balcony projects to the largest commercial schemes, Balcony Systems aims to deliver inspirational solutions that can truly transform buildings and outdoor spaces.

From individual balcony projects to the largest commercial schemes, Balcony Systems aim to deliver inspirational solutions that can truly transform buildings and outdoor spaces.



BALCONY



- Glass Balustrades
- Juliet Balconies
- Curved Patio Doors
- BalcoNano® Self-Cleaning Glass Coating
- Composite Decking

For more information
please contact us:

T: 01342 410411

E: sales@balconette.co.uk

www.balconette.co.uk

Balcony Systems Solutions Ltd
Unit 6 Systems House
Eastbourne Road
Blindley Heath
Surrey
RH7 6JP

